



TITAN FLOW CONTROL, INC.

CHECK VALVE ♦ WAFER TYPE ♦ DUAL DISC**ASME CLASS 150 ♦ DUCTILE IRON BODY ♦ NSF COATING****MODEL: CV 41A-DI**

Body: Ductile Iron

Seats: Buna, Viton & EPDM

Discs: Stainless Steel & Aluminum Bronze

**NEWLY
DESIGNED...**
Meets API 594

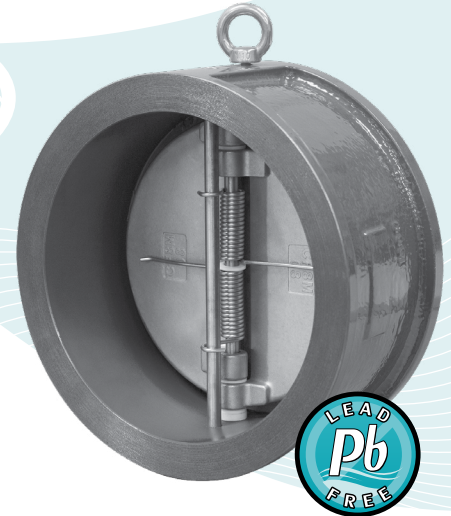
**FEATURES****SIZES: 2" ~ 24"**LARGER SIZES AVAILABLE
UPON REQUEST♦ **COMPLIES WITH API 594 DIMENSIONS**

THE CV41A-DI MEETS API 594 ASME CLASS 125 FACE-TO-FACE DIMENSIONS. THIS ALLOWS THE CV41A-DI TO BE A NATURAL REPLACEMENT FOR OUTDATED CAST IRON VALVES WHILE ACHIEVING THE SUPERIOR MATERIAL BENEFITS OF DUCTILE IRON.

♦ **NSF APPROVED COATING**

THE BODY OF THIS VALVE IS PROVIDED WITH A DURABLE EPOXY COATING. THIS COATING OFFERS HIGH-BUILD EDGE PROTECTION AND EXCELLENT CORROSION RESISTANCE. THIS COATING IS CERTIFIED BY NSF INTERNATIONAL IN ACCORDANCE WITH NSF/ASME STANDARD 61.

♦ **DUCTILE IRON BODY**

DUCTILE IRON BODY MAINTAINS THE ANTI-CORROSIVE PROPERTIES OF CAST IRON WHILE ACHIEVING A YIELD STRENGTH COMPARABLE TO CARBON STEEL. DUCTILE IRON ALSO OFFERS HIGHER PRESSURE/TEMPERATURE RATINGS THAN CAST IRON.

♦ **COST EFFICIENT DESIGN**

LOW WEIGHT AND SHORT LAYING LENGTH PRODUCE SAVINGS IN INITIAL COST, SPACE REQUIREMENTS, AND INSTALLATION WHEN COMPARED TO FULL-BODY, SWING-TYPE CHECK VALVES.

♦ **MINIMAL HEAD LOSS**

CONTOUR OF BODY PROVIDES A SHORT AND STRAIGHT FLOW PATH THAT GENERATES VERY LITTLE TURBULENCE. ADDITIONALLY, THE SPRING-LOADED DISCS ARE DESIGNED WITH VERY LOW CRACKING PRESSURE WHICH REDUCES THE AMOUNT OF ENERGY REQUIRED TO OPEN THE VALVE.

♦ **QUICK CLOSURE TO REDUCE WATER HAMMER**

SHUT-OFF IS ACHIEVED VIA THE FULLY AUTOMATIC, SPRING-ASSISTED DISCS THAT CLOSE NEAR ZERO FLOW VELOCITY. THE LIGHTWEIGHT, SPLIT DISC DESIGN CREATES A POSITIVE SHUTOFF PRIOR TO FLOW REVERSAL AND HELPS TO KEEP SLAMMING AND SURGES TO A MINIMUM.

TECHNICAL

PRESSURE/TEMPERATURE RATING
DI - ASTM A536 - CLASS 150 - 2" ~ 24"

WOG (Non-shock): 250 PSI @ 100 °F

SEAT MATERIAL
TEMPERATURE RANGE

EPDM: -20 ~ 300 °F
BUNA-N: -20 ~ 250 °F
VITON: -40 ~ 400 °F

SPRING MATERIAL
MAXIMUM TEMPERATURE

SS ASTM A182 Gr. 316: 450 °F

CV 41A meets AWWA C518 Face-to-Face Dimensions.

1. The above listed temperatures are theoretical and may vary during actual operating conditions.
2. Max and min temperatures are for reference only. Prolonged use at these temperatures is not recommended for optimal service life.

APPLICATIONS

BUNA-N PROPERTIES: MOST WIDELY USED ELASTOMER. GOOD FOR MOST PETROLEUM OILS AND FLUIDS, SILICONE GREASES AND OILS, AND COLD WATER. EXCELLENT COMPRESSION SET, TEAR, AND ABRASION RESISTANCE. POOR WEATHER RESISTANCE AND MODERATE HEAT RESISTANCE. NOT RECOMMENDED FOR SEVERE OZONE-RESISTANT APPLICATIONS.

VITON PROPERTIES: OFFERS A BROAD RANGE OF CHEMICAL RESISTANCE AND EXCELLENT HEAT RESISTANCE. GOOD MECHANICAL PROPERTIES AND COMPRESSION SET RESISTANCE. OFTEN USED IN APPLICATIONS WHERE NOTHING ELSE WILL WORK. FAIR LOW TEMPERATURE RESISTANCE AND LIMITED HOT-WATER RESISTANCE AND SHRINKAGE.

EPDM PROPERTIES: PROBABLY THE MOST WATER RESISTANT RUBBER AVAILABLE. IT HAS GOOD RESISTANCE TO MILD ACIDS, ALKALIS, SILICONE OILS/GREASES, KETONES, ALCOHOLS AND OTHER POLAR SOLVENTS. IT IS NOT RECOMMENDED FOR USE WITH PETROLEUM OILS, DI-ESTER LUBRICANTS, MINERAL OILS, NON-POLAR SOLVENTS OR AROMATIC FUELS.

The above data represents common market and service applications. No representation or guarantee, expressed or implied, is given due to the numerous variations of concentrations, temperatures and flow conditions that may occur during actual service.

TITAN® FLOW CONTROL, INC.**YOUR PIPELINE TO THE FUTURE!**

Tel: 910-735-0000 ♦ Fax: 910-738-3848 ♦ titan@titanfci.com ♦ www.titanfci.com
290 Corporate Drive ♦ PO Box 7408 ♦ Lumberton, NC 28358



TITAN® FLOW CONTROL, Inc.

290 Corporate Drive
Lumberton, NC 28358
Tel: 910.735.0000

E-mail: titan@titanfci.com
Web: www.titanfci.com
Fax: 910.738.3848

CHECK VALVE • WAFER TYPE • DUAL DISC

MODEL: CV 41A-DI (Ductile Iron Body)

Buna-N, Viton, or EPDM Seats
Stainless Steel or Bronze Discs

ASME
Class
150

BILL OF MATERIALS (1)

| No. | PART | CV 41A-DI (3) |
|-----|----------------|---|
| 1 | Body | Ductile Iron ASTM A536 |
| 2 | Seat(5) | Buna-N/Viton/EPDM |
| 3 | Disc (2) | Aluminum Bronze ASTM B148 / Stainless Steel ASTM A351 Gr. CF8M |
| 4 | Spring (2) | Stainless Steel ASTM A182 Gr. 316 |
| 5 | Shaft/Stop Pin | Stainless Steel ASTM A182 Gr. 316 |
| 6 | Set Screw | Galvanized Carbon Steel |
| 7 | Eye Bolt (4) | Carbon Steel (Not Shown) |
| 8 | Seal Plug | Buna-N/Viton/EPDM |

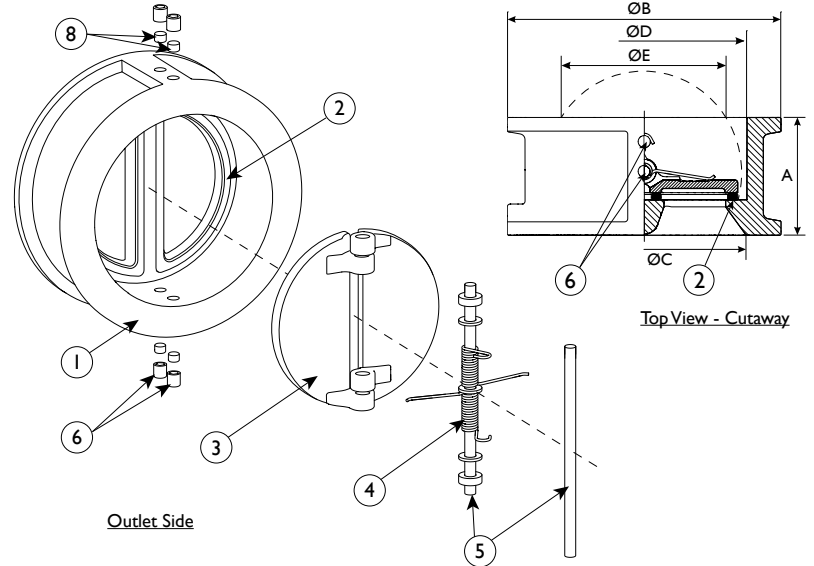

1. Bill of Materials represents standard materials. Equivalent or better materials may be substituted at the manufacturer's discretion.
2. Denotes recommended spare parts.
3. Ductile Iron bodies are NSF coated.
4. Eye Bolt is available on larger sizes only.

Ductile Iron Application Notes:

Ductile Iron maintains the anti-corrosive properties of Cast Iron while achieving a yield strength comparable to Carbon Steel. Ductile Iron also offers higher pressure/temperature ratings than Cast Iron. Ductile Iron ASME Class 150 has the same bolting pattern as Cast Iron ASME Class 125.

DIMENSIONS AND PERFORMANCE DATA (1)

| SIZE | in | 2 | 2 1/2 | 3 | 4 | 5 | 6 | 8 | 10 | 12 | 14 | 16 | 18 | 20 | 24 |
|--|----------------|-------|-------|-------|-------|-------|-------|-------|-------|-------|-------|-------|-------|-------|-------|
| | mm | 50 | 65 | 80 | 100 | 125 | 150 | 200 | 250 | 300 | 350 | 400 | 450 | 500 | 600 |
| A DIMENSION FACE TO FACE (2) | in | 2.12 | 2.38 | 2.62 | 2.62 | 3.25 | 3.75 | 5.00 | 5.50 | 7.12 | 7.25 | 7.50 | 8.00 | 8.38 | 8.75 |
| | mm | 54 | 60 | 67 | 67 | 83 | 95 | 127 | 140 | 181 | 184 | 191 | 203 | 213 | 222 |
| ØB DIMENSION OUTLET OUTSIDE DIAMETER | in | 4.02 | 4.76 | 5.24 | 6.73 | 7.60 | 8.62 | 10.87 | 13.23 | 15.98 | 17.64 | 20.12 | 21.50 | 23.74 | 28.11 |
| | mm | 102 | 121 | 133 | 171 | 193 | 219 | 276 | 336 | 406 | 448 | 511 | 546 | 603 | 714 |
| ØC DIMENSION INLET INSIDE DIAMETER | in | 2.17 | 2.92 | 3.45 | 4.12 | 5.67 | 6.43 | 8.56 | 10.43 | 12.21 | 14.17 | 16.13 | 17.32 | 20.10 | 23.66 |
| | mm | 55 | 74 | 88 | 105 | 144 | 163 | 217 | 265 | 310 | 360 | 410 | 440 | 511 | 601 |
| ØD DIMENSION OUTLET INSIDE DIAMETER | in | 2.58 | 3.15 | 3.70 | 4.61 | 5.71 | 6.69 | 8.82 | 10.43 | 12.20 | 14.17 | 16.14 | 17.72 | 19.88 | 24.57 |
| | mm | 66 | 80 | 94 | 117 | 145 | 170 | 224 | 265 | 310 | 360 | 410 | 450 | 505 | 624 |
| ØE DIMENSION MINIMUM BORE DIAMETER | in | 1.66 | 2.28 | 2.78 | 3.38 | 4.53 | 5.49 | 7.40 | 9.14 | 10.65 | 12.97 | 14.63 | 16.26 | 18.17 | 22.62 |
| | mm | 42 | 58 | 71 | 86 | 115 | 140 | 188 | 232 | 271 | 330 | 372 | 413 | 462 | 575 |
| ASSEMBLED WEIGHT | lb | 3.3 | 5.2 | 7.0 | 14.0 | 18.0 | 26.5 | 43.0 | 70.0 | 108.0 | 175.0 | 200.0 | 258.0 | 345.0 | 460.0 |
| | kg | 1.5 | 2.4 | 3.2 | 6.4 | 8.2 | 12.0 | 19.5 | 31.7 | 48.9 | 79.4 | 90.7 | 117.0 | 156.5 | 208.7 |
| Flow Coefficient | C _v | 62 | 110 | 175 | 350 | 550 | 850 | 1500 | 2400 | 3700 | 5400 | 8250 | 10400 | 14200 | 23000 |
| Cracking Pressure (3) | psi | ≤ .25 | ≤ .25 | ≤ .25 | ≤ .25 | ≤ .25 | ≤ .25 | ≤ .25 | ≤ .25 | ≤ .25 | ≤ .25 | ≤ .25 | ≤ .25 | ≤ .25 | ≤ .25 |

1. Dimensions and weights are for reference only. When required, request certified drawings.
2. Face to face values have a tolerance of ±0.06 in (±0.20 mm) for sizes 10" and lower and a tolerance of ±0.12 in (±3.0 mm) for sizes 12" and larger.
3. Cracking pressure is for horizontal installations only. For vertical installations, please consult factory.

PRESSURE - TEMPERATURE RATINGS (1)

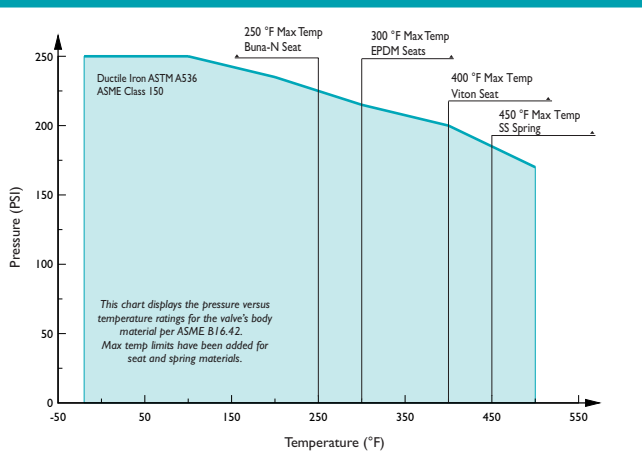

1. The maximum temperature for ASTM A536 Grade 65-45-12 is 500 °F (ASME B16.42 2021 ed.)

REFERENCED STANDARDS & CODES

| CODE | DESCRIPTION |
|-------------|--|
| API 594 | Valve Design and Manufacture |
| AWWA C518 | Face-to-Face Dimensions |
| ASME B16.34 | Valves - Flanged, Threaded, and Welding End |
| ASME B16.42 | Ductile Iron Pipe Flanges and Flanged Fittings |
| API 598 | Valve Inspection and Pressure Test |

PRESSURE / TEMPERATURE RATING - ASTM A536

| | |
|-------------------------|-----------------------------|
| Body Material | Class 150 (2" ~ 24") |
| WOG (Non-shock): | 250 PSI @ 100 °F |

SEAT AND SPRING TEMPERATURE RATING

| Seat Material | Range | Spring Material | Max |
|---------------|--------------|-----------------------|--------|
| EPDM: | -30 ~ 300 °F | SS ASTM A182 Gr. 316: | 450 °F |
| BUNA-N: | -20 ~ 250 °F | | |
| VITON: | -40 ~ 400 °F | | |

1. Max and min temperatures are for reference only. Prolonged use at these temperatures is not recommended for optimal service life.

As †Titan product changes occur, there may be short-term differences between actual product specifications and the information contained within our literature. †Titan FCI reserves the right to make design and specification changes to improve our products without prior notification. When required, request certified drawings. †TITAN is a registered trademark of Titan Flow Control Incorporated.