

Submittal Package

Viega MegaPress Stainless 304



Project _____ **Date** _____

Engineer _____ **Contractor** _____

Submitted by _____

Approved by _____ **Date** _____ **Approved by** _____ **Date** _____

Table of Contents

- Chilled Water
- Hydronic Heating
- Fire Protection
- Low-Pressure Steam
- Compressed Air
- Industrial Gases
- Vacuum
-

1	System Data Sheet _____	3
	MegaPress Stainless 304 _____	3
2	Product Instructions _____	4
	MegaPress Stainless 304 ½" to 2" Fittings _____	4
	MegaPress Stainless 304 2½" to 4" Fittings _____	5
3	Engineering Specifications _____	6
	MegaPress Stainless _____	6
4	Dimensional Documents _____	10
	MegaPress Stainless 304 ½" to 2" Fittings _____	10
	MegaPress Stainless 304 2½" to 4" Fittings _____	15



This document is subject to updates. For the most current Viega technical literature please visit www.viega.us.



Viega products are designed to be installed by licensed and trained plumbing and mechanical professionals who are familiar with Viega products and their installation. **Installation by non-professionals may void Viega LLC's warranty.**

1 System Data Sheet

MegaPress Stainless 304



Viega MegaPress Stainless 304 fittings are designed to be used with off the shelf Schedule 10 to Schedule 40 stainless steel pipe to form a complete press system that is ideal for industrial applications. A Viega MegaPress Stainless 304 system can stand up to harsh environments while transporting

process water, diesel fuel, lube oil, ammonia, low pressure steam, or any number of other essential fluids or gases.

Viega MegaPress Stainless 304 fittings in sizes from 1/2" to 4" are offered in configurations including: elbows, couplings, reducers, tees, reducing tees, threaded adapters, unions, caps, and flanges.

Components

- Alloy: 304 stainless steel
- FKM sealing element
- 420 stainless steel grip ring
- 304 stainless steel separator ring for 1/2" to 2" fittings
- PBT separator ring for 2 1/2" to 4" fittings

Operating Parameters

- Operating Pressure: 200 psi max
- Test Pressure: 600 psi max
- Operating Temperatures: 14°F to 284°F
(with temperature spikes up to 356°F)

Listings and Certificates

- | | |
|----------------------------|---------------------|
| ■ ABS type approval | ■ IAPMO PS-117 |
| ■ ASME B31.1, B31.3, B31.9 | ■ ICC-ES LC1002 |
| ■ BV (Bureau Veritas) | ■ Lloyds Register |
| ■ CRN 13492.5 A/B/C | ■ NFPA 13, 13D, 13R |
| ■ DNV-GL | ■ UL/ANSI 213 |
| ■ FM Class 1920 | ■ ULC/ANSI ORD-C213 |

Compliant with:

- ASME B31
- ASTM A312
- ASTM A554
- IAPMO Uniform Mechanical Code (UMC)
- ICC International Mechanical Code (IMC)
- ICC International Residential Code (IRC)
- National Building Code of Canada (NBCC)
- National Plumbing Code of Canada (NPCC)

Approved Applications

- Process Water (non-potable)
- Low Pressure Steam
- Industrial Gases
- Compress Air (no oil)
- Lube Oil
- Caustic Solutions
- Acid Solutions
- Vacuum

For more specific information on applications for MegaPress Stainless 304, contact Viega Technical Services at 1-800-976-9819.

Viega MegaPress Stainless 304 systems are approved for underground use. When installed underground, Viega MegaPress 304 should have proper corrosion protection in accordance with local and national codes.

Recommended Tools

- Standard size press tool (minimum hydraulic ram output of 7200 lbs.)
- #56013 MegaPress jaw/ring kit (1/2" to 2")
- #26200 MegaPress XL PressBooster with 2 1/2" press ring
- #26201 MegaPress XL 3" and 4" press ring kit

Smart Connect® Technology

Viega MegaPress Stainless 304 fittings are manufactured with Viega's patented Smart Connect® technology. Designed into the fitting itself, Viega Smart Connect technology allows identification of an unpressed fitting during pressure testing.



This document is subject to updates. For the most current Viega technical literature please visit www.viega.us.



Viega products are designed to be installed by licensed and trained plumbing and mechanical professionals who are familiar with Viega products and their installation.

Installation by non-professionals may void Viega LLC's warranty.

2 Product Instructions

MegaPress Stainless 304 1/2" to 2" Fittings

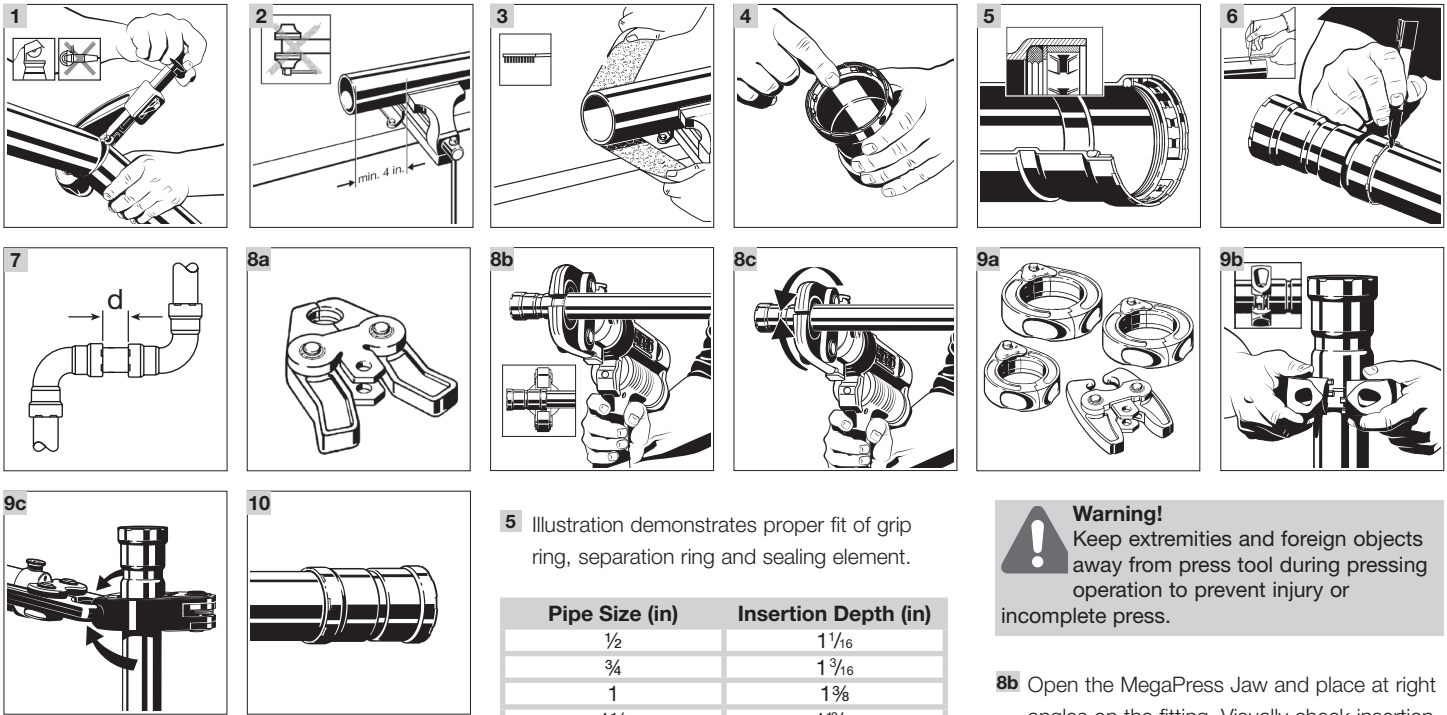

! Viega products are designed to be installed by licensed and trained plumbing and mechanical professionals who are familiar with Viega products and their installation. **Installation by non-professionals may void Viega LLC's warranty.**

- 1 Cut piping at right angles using displacement type cutter.
- 2 Keep end of piping a minimum of 4" away from the contact area of the vise to prevent possible damage to the piping in the press area. See MegaPress Manual for minimum clearance required for prep tools.
- 3 Remove burr from inside and outside of piping and prep to proper insertion depth using a preparation tool or fine grit sandpaper.
- 4 Check seal and grip ring for correct fit. Do not use oils or lubricants.

5 Illustration demonstrates proper fit of grip ring, separation ring and sealing element.

Pipe Size (in)	Insertion Depth (in)
1/2	1 1/16
3/4	1 3/16
1	1 3/8
1 1/4	1 13/16
1 1/2	1 7/8
2	2

- 6 Mark proper insertion depth. Improper insertion depth may result in an improper seal. The depth marking shall be visible on the completed assembly.
- 7 Refer to chart for minimum distance between fittings. To ensure a correct press, a minimum distance between press fittings must be maintained. Failure to provide this distance may result in an improper seal.

Pipe Diameter (in)	d (in)
1/2	1/4
3/4	1/4
1	1/4
1 1/4	1/2
1 1/2	1/2
2	1/2

8a Viega MegaPress 1/2" - 1" fitting connections must be performed with MegaPress Jaws. See RIDGID Operator's Manual for proper tool instructions.

Warning! Keep extremities and foreign objects away from press tool during pressing operation to prevent injury or incomplete press.

- 8b Open the MegaPress Jaw and place at right angles on the fitting. Visually check insertion depth using mark on piping.
- 8c Start pressing process and hold the trigger until the jaw has engaged the fitting.
- 9a Viega MegaPress 1 1/4" - 2" fitting connections must be performed with MegaPress Rings and V2 Actuator. See Operator's Manual for proper tool instructions.
- 9b Open MegaPress Ring and place at right angles on the fitting. MegaPress Ring must be engaged on the fitting bead. Check insertion depth.
- 9c Place V2 Actuator onto MegaPress Ring and start pressing process. Hold the trigger until the Actuator has engaged the MegaPress Ring.
- 10 Remove MegaPress Jaw from fitting or release V2 Actuator from RIDGID MegaPress Ring and then remove MegaPress Ring from the fitting on completion of press. Remove control label to indicate press has been completed.

Product Instructions

MegaPress Stainless 304 2½" to 4" Fittings

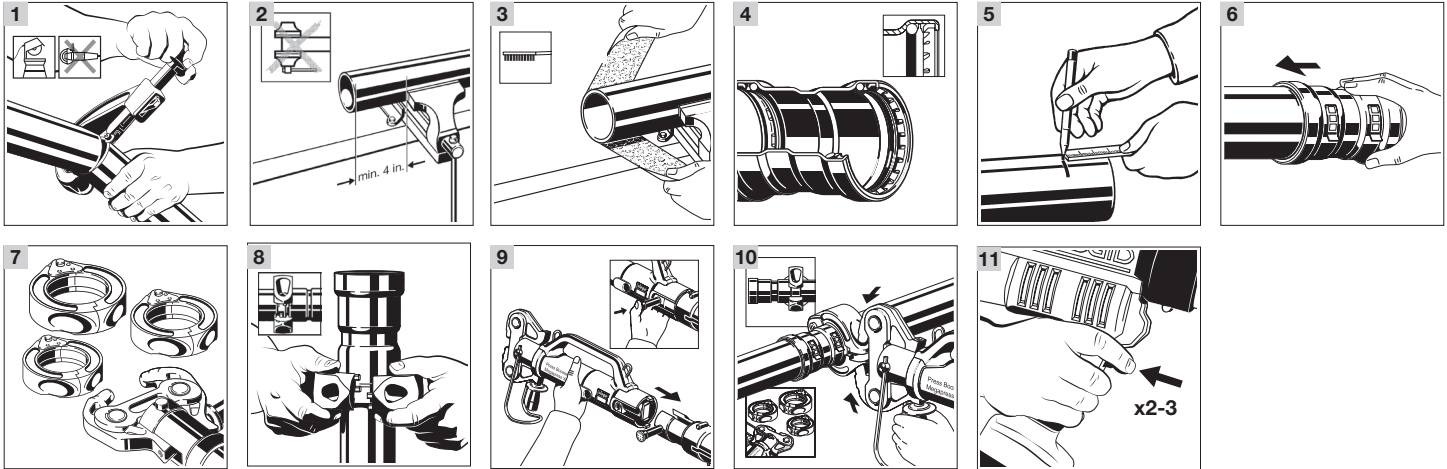

! Viega products are designed to be installed by licensed and trained plumbing and mechanical professionals who are familiar with Viega products and their installation. **Installation by non-professionals may void Viega LLC's warranty.**

- 1 Cut piping at right angles using displacement type cutter.
- 2 Keep end of piping a minimum of 4" away from the contact area of the vise to prevent possible damage to the piping in the press area. See MegaPress Manual for minimum clearance required for prep tools.
- 3 Remove burr from inside and outside of piping and prep to proper insertion depth using a preparation tool or fine grit sandpaper.
- 4 Illustration demonstrates proper fit of grip ring, separation ring and sealing element.

- 5 Mark proper insertion depth. Improper insertion depth may result in an improper seal. The depth marking shall be visible on the completed assembly.

Insertion Depth (in)	d (in)
2½	1 ¹³ / ₁₆
3	2 ⁵ / ₁₆
4	3 ¹ / ₈

- 6 While turning slightly, slide fitting onto tubing to the marked depth. End of tubing must contact stop.
- 7 Viega MegaPress 2½" - 4" fitting connections must be made using MegaPress XL Rings and a PressBooster/Z3 actuator. See Operator's Manual for proper tool instructions.

Warning! Keep extremities and foreign objects away from press tool during pressing operation to prevent injury or incomplete press.

- 8 Open MegaPress Ring and place at right angles on the fitting. MegaPress Ring must be engaged on the fitting bead. Check insertion depth.
- 9 Remove the retaining bolt of the press machine. Slide the PressBooster in via the press jaw fixture.
- 10 Place PressBooster/Z3 actuator onto MegaPress XL Rings and start pressing process. Hold the trigger until the Actuator has engaged the MegaPress Ring.
- 11 The PressBooster requires two presses of the trigger to execute a complete press. A third press may be needed to initiate a release cycle to reset the rollers back to the original position.

3 Engineering Specifications

MegaPress Stainless



This document is subject to updates. For the most current Viega technical literature please visit www.viega.us.



Viega products are designed to be installed by licensed and trained plumbing and mechanical professionals who are familiar with Viega products and their installation. **Installation by non-professionals may void Viega LLC's warranty.**

Part 1: General

1.1 Summary

- A. Stainless steel pipe and fitting system using cold press connection technology. The system is assembled when the pipe is fully inserted into the fitting, then the fitting is pressed onto the pipe using the manufacturer's approved tooling, creating a mechanical joint. Press system for use with schedule 5 to schedule 40 stainless steel pipe in sizes ½" to 4".

1.2 Definitions

- A. ASME: American Society of Mechanical Engineers
- B. ASTM: American Society for Testing and Materials
- C. AWWA: American Water Works Association
- D. EPDM: Ethylene Propylene Diene Monomer
- E. FKM: Fluoroelastomer
- F. IAPMO: International Association of Plumbing and Mechanical Officials
- G. ICC: International Code Council
- H. MSS: Manufacturers Standardization Society
- I. NSF: National Sanitation Foundation
- J. psi: Pounds per Square Inch

1.3 References

- A. ASME A13.1 Scheme for the Identification of Piping Systems
- B. ASME B1.20.1 Pipe Threads, General Purpose (Inch)
- C. ASME B31.1 Power Piping
- D. ASME B31.3 Process Piping
- E. ASME B31.9 Building Services Piping
- F. ASTM A312 Standard Specification for Seamless, Welded, and Heavily Cold Worked Austenitic Stainless Steel Pipes
- G. ASTM A403 Standard Specification for Wrought Austenitic Steel Piping Fittings.
- H. AWWA C651 Standard for Disinfecting Water Mains
- I. IAPMO Uniform Mechanical Code
- J. IAPMO Uniform Plumbing Code
- K. IAPMO PS-117 Press and Nail Connections
- L. ICC International Plumbing Code
- M. ICC International Mechanical Code
- N. MSS-SP-58 Pipe Hangers and Supports - Materials, Design and Manufacture
- O. NSF 61 Drinking Water System Components – Health Effects

1.4 Quality Assurance

- A. The installer shall be a qualified installer, licensed within the jurisdiction, and familiar with the installation of stainless steel pipe.
- B. The installation of stainless steel pipe for hot and cold water distribution systems shall conform to the requirements of the ICC International Plumbing Code or IAPMO Uniform Plumbing Code. The installation of stainless steel pipe in hydronic systems shall conform to the requirements of the ICC International Mechanical Code or the IAPMO Uniform Mechanical Code.

1.5 Delivery, Storage, and Handling

- A. Stainless steel pipe shall be shipped to the job site by truck or in such a manner to protect the pipe. The pipe and fittings shall not be handled roughly during shipment. The pipe and fittings shall be unloaded with reasonable care.
- B. Protect the stored pipe from moisture and dirt. Elevate above grade. When stored inside, do not exceed the structural capacity of the floor.
- C. Protect fittings and piping specialties from moisture and dirt.

1.6 Project Conditions

- A. Verify length of pipe required by field measurements.

1.7 Warranty

- A. The pipe and fittings manufacturer shall warrant that the pipe and fittings are free from defects and conform to the designated standard. The warranty shall only be applicable to pipe and fittings installed in accordance with the manufacturer's installation instructions.
- B. The manufacturer of the pipe and fittings shall not be responsible for the improper use, handling, or installation of the product.

Part 2: Products

2.1 Manufactures

- A. Stainless Steel Press Fittings:
Viega LLC
585 Interlocken Blvd.
Broomfield CO, 80021
Telephone (316) 425-7400
Website: www.viega.us

2.2 Material

- A. Pipe standard: stainless steel pipe shall conform to ASTM A312.
- B. Fitting standard: stainless steel fittings shall conform to the material requirements of ASTM A312 or ASTM A403.
- C. Press fitting: stainless steel press fittings shall conform to the material and sizing requirements of ASME A312 or ASTM A403. O-rings for stainless steel press fittings shall be EPDM, or FKM, depending on the application.
- D. Threaded fittings: pipe threads shall conform to ASME B1.20.1.
- E. Hanger standard: hangers and supports shall conform to MSS-SP-58.

2.3 Source Quality Control

- A. All pipe, fittings, and joining materials in contact with drinking water shall be listed by a third party agency to NSF 61.

Part 3: Execution

3.1 Examination

- A. The installing contractor shall examine the stainless steel pipe and fittings for defects or cracks. There shall be no defects of the pipe or fittings. Any damaged pipe or fittings shall be rejected.

3.2 Preparation

- A. Stainless steel pipe shall be cut with a wheeled pipe cutter or approved stainless steel pipe cutting tool. The pipe shall be cut square to permit proper joining with the fittings.
- B. Remove scale, slag, dirt, and debris from inside and outside of pipe and fittings before assembly. The pipe end shall be wiped clean and dry. The burrs on the pipe shall be reamed with a deburring or reaming tool.

3.3 Installation General Locations

- A. Plans indicate general location and arrangement of piping systems. Identified locations and arrangements are used to size pipe and calculate friction loss, expansion, pump sizing, and other design considerations. Install piping as indicated, except where deviations to layout are approved on coordination drawings.

3.4 Installation, Stainless Steel Pipe

- A. Pressure rating: install components having a pressure rating equal to or greater than the system operating pressure.
- B. Install piping free of sags, bends, and kinks.
- C. Change in direction: install fittings for changes in direction and branch connections.
- D. Press connections: stainless steel press fittings shall be made in accordance with the manufacturer's installation instructions. The pipe shall be fully inserted into the fitting and the pipe marked at the shoulder of the fitting. The fitting alignment shall be checked against the mark on the pipe to assure the pipe is fully engaged (inserted) in the fitting. The joints shall be pressed using the tool approved by the manufacturer.
- E. Threaded joints: threaded joints shall have pipe joint compound or teflon tape applied to the male threads only. Tighten joint with a wrench and backup wrench as required.
- F. Pipe protection: provide protection against abrasion where stainless steel pipe is in contact with other building members by wrapping with an approved tape, pipe insulation, or otherwise suitable method of isolation.
- G. Penetration protection: provide allowance for thermal expansion and contraction of stainless steel pipe passing through a wall, floor, ceiling, or partition by wrapping with an approved tape or pipe insulation, or by installing through an appropriately sized sleeve. Penetrations of fire resistance rated assemblies shall maintain the rating of the assembly.
- H. Backfill material: backfill material shall not include any ashes, cinders, refuse, stones, boulders or other materials which can damage or break the pipe or promote corrosive action in any trench or excavation in which pipe is installed.
- I. Horizontal support: install hangers for horizontal piping in accordance with local code or the following maximum spacing and minimum rod sizes:

Nominal Pipe Size (in)	Stainless Steel Pipe Maximum Span (ft)	Minimum Rod Diameter (in)
Up to ¾	10	⅜
1	10	⅜
1¼	10	⅜
1½	10	⅜
2	10	⅜
2½	11	½
3	12	½
4	14	⅝

All systems must be installed per local codes and/or standards and requirements. Consult the Viega Technical Support department before installing the system in other applications or applications with temperatures and/or pressures outside the stated ratings. Refer to Viega's Application Guide for more information.

- J. Vertical support: vertical stainless steel pipe shall be supported at each floor or at 10 foot intervals.
- K. Galvanic corrosion: hangers and supports shall be either stainless steel or vinyl coated to prevent galvanic corrosion between the pipe and the supporting member.
- L. Restraint: in seismic areas, stainless steel pipe shall be installed to withstand all seismic forces.
- M. Identification: stainless steel pipe systems shall be identified in accordance with the requirements of ASME A13.1.

3.5 Field Quality Control

- A. Viega MegaPress Stainless fittings include Smart Connect® technology, a quick and easy way of identifying unpressed connections during the pressure testing process. The function of the feature is to provide identification of connections which have not been pressed prior to putting the system in to operation. The function of Smart Connect technology is carried out by pressurizing the piping system. Smart Connect technology may be pressure tested with air or water.
 - When testing with air, the pressure range is ½ psi to 45 psi maximum.
 - When testing with water, the pressure range is 15 psi to 85 psi maximum.
- B. The Smart Connect technology test is not a substitute for local code required pressure testing of the piping system. Carry out the final piping system pressure test in accordance with local codes.

3.6 Cleaning (Potable Water Systems)

- A. Disinfection: the stainless steel hot and cold water distribution system shall be disinfected prior to being placed in service. The system shall be disinfected in accordance with AWWA C651 or the following requirements:
 1. The piping system shall be flushed with potable water until discolored water does not appear at any of the outlets.
 2. The system shall be filled with a water chlorine solution containing between 50 and 200 parts per million of chlorine. The system shall be valved in the closed position and allowed to stand for 24 hours.
 3. Following the standing time, the system shall be flushed with water until the chlorine is purged from the system.

4 Dimensional Documents

MegaPress Stainless 304 ½" to 2" Fittings



This document is subject to updates. For the most current Viega technical literature please visit www.viega.us.



Viega products are designed to be installed by licensed and trained plumbing and mechanical professionals who are familiar with Viega products and their installation. **Installation by non-professionals may void Viega LLC's warranty.**

MegaPress 90° Elbow, Stainless Steel, P x P - Models 4116 / 5116

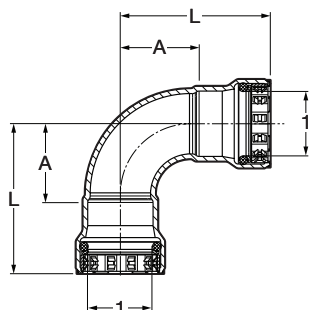

Part No.		Size (in)	A (in)	L (in)
304	316	1		
95005	90005	½	1.17	2.24
95010	90010	¾	1.36	2.52
95015	90015	1	1.72	3.07
95020	90020	1½	2.26	4.13
95025	90025	2	2.80	4.78

MegaPress 90° Elbow, Stainless Steel, FTG x P - Models 4116.1 / 5116.1

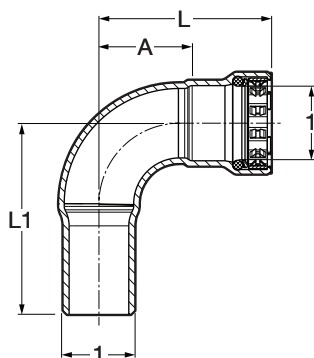

Part No.		Size (in)	A (in)	L (in)	L1 (in)
304	316	1			
95030	90030	½	1.17	2.24	2.56
95035	90035	¾	1.36	2.52	2.87
95040	90040	1	1.72	3.07	3.39
95045	90045	1½	2.26	4.13	4.21
95050	90050	2	2.80	4.78	5.08

MegaPress 45° Elbow, Stainless Steel, P x P - Models 4126 / 5126

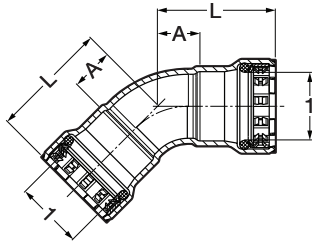

Part No.		Size (in)	A (in)	L (in)
304	316	1		
95055	90055	1/2	0.60	1.67
95060	90060	3/4	0.71	1.87
95065	90065	1	0.86	2.20
95070	90070	1 1/2	1.12	2.99
95075	90075	2	1.32	3.31

MegaPress 45° Elbow, Stainless Steel, FTG x P - Models 4126.1 / 5126.1

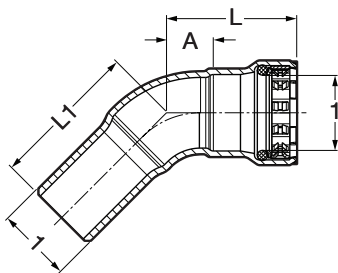

Part No.		Size (in)	A (in)	L (in)	L1 (in)
304	316	1			
95080	90080	1/2	0.60	1.67	1.97
95085	90085	3/4	0.71	1.87	2.13
95090	90090	1	0.86	2.20	2.52
95095	90095	1 1/2	1.12	2.99	3.07
95100	90100	2	1.32	3.31	3.58

MegaPress Tee, Stainless Steel, P x P x P - Models 4118 / 5118

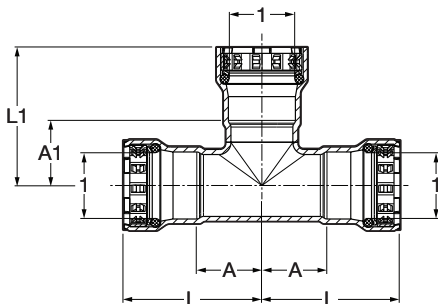

Part No.		Size (in)	A (in)	A1 (in)	L (in)	L1 (in)
304	316	1				
95105	90105	1/2	0.97	0.93	2.04	2.00
95110	90110	3/4	1.11	1.09	2.26	2.24
95115	90115	1	1.23	1.23	2.57	2.57
95120	90120	1 1/2	1.57	1.54	3.44	3.41
95125	90125	2	1.81	1.80	3.80	3.79

MegaPress Reducing Tee, Stainless Steel, P x P x P - Models 4118 / 5118

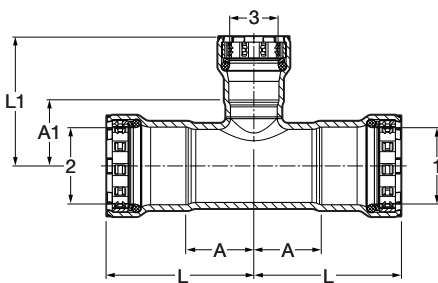

Part No.		Size (in)	A (in)	A1 (in)	L (in)	L1 (in)
304	316	1 2 3				
95130	90130	3/4 x 3/4 x 1/2	1.11	1.07	2.26	2.14
95135	90135	1 x 1 x 1/2	1.23	1.20	2.57	2.28
95140	90140	1 x 1 x 3/4	1.23	1.24	2.57	2.40
95145	90145	1 1/2 x 1 1/2 x 1/2	1.57	1.44	3.44	2.51
95150	90150	1 1/2 x 1 1/2 x 3/4	1.57	1.48	3.44	2.64
95155	90155	1 1/2 x 1 1/2 x 1	1.57	1.48	3.44	2.83
95160	90160	2 x 2 x 1/2	1.81	1.74	3.80	2.81
95165	90165	2 x 2 x 3/4	1.81	1.80	3.80	2.95
95170	90170	2 x 2 x 1	1.81	1.75	3.80	3.10
95175	90175	2 x 2 x 1 1/2	1.81	1.84	3.80	3.71

MegaPress Reducing Tee, Stainless Steel, P x P x FPT - Models 4117.2 / 5117.2

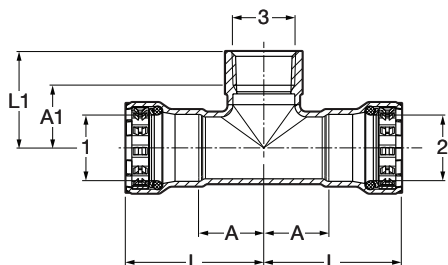

Part No.		Size (in)			A (in)	A1 (in)	L (in)	L1 (in)
304	316	1	2	3				
95180	90180	3/4	3/4	1/2	1.11	1.02	2.26	1.55
95185	90185	3/4	3/4	3/4	1.11	1.03	2.26	1.58
95190	90190	1	1	1/2	1.23	1.19	2.57	1.73
95195	90195	1	1	3/4	1.23	1.18	2.57	1.73
95200	90200	1 1/2	1 1/2	1/2	1.57	1.42	3.44	1.95
95205	90205	1 1/2	1 1/2	3/4	1.57	1.41	3.44	1.97
95210	90210	1 1/2	1 1/2	1	1.57	1.57	3.44	2.24
95215	90215	2	2	1/2	1.81	1.70	3.80	2.24
95220	90220	2	2	3/4	1.81	1.72	3.80	2.28
95225	90225	2	2	1	1.81	1.89	3.80	2.55

MegaPress Adapter, Stainless Steel, P x MPT - Models 4111 / 5111

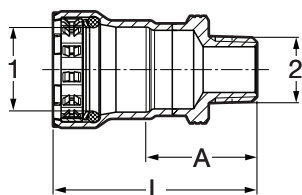

Part No.		Size (in)		A (in)	L (in)
304	316	1	2		
95230	90230	1/2	1/2	1.45	2.52
95235	90235	3/4	1/2	1.49	2.65
95240	90240	3/4	3/4	1.50	2.66
95245	90245	1	1	1.66	3.00
95250	90250	1 1/2	1 1/2	1.93	3.80
95255	90255	2	2	1.93	3.92

MegaPress Adapter, Stainless Steel, P x FPT - Models 4112 / 5112

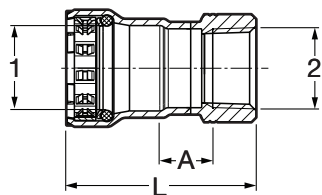

Part No.		Size (in)		A (in)	L (in)
304	316	1	2		
95260	90260	1/2	1/2	0.69	2.29
95265	90265	3/4	3/4	0.74	2.45
95270	90270	1	1	0.73	2.74
95275	90275	1 1/2	1 1/2	0.72	3.28
95280	90280	2	2	0.76	3.44

MegaPress Coupling with Stop, Stainless Steel, P x P - Models 4115 / 5115

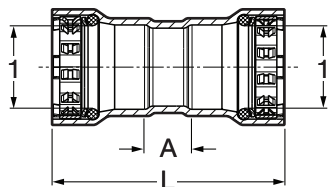

Part No.		Size (in)	A (in)	L (in)
304	316	1		
95285	90285	1/2	0.56	2.70
95290	90290	3/4	0.63	2.94
95295	90295	1	0.59	3.29
95300	90300	1 1/2	0.89	4.63
95305	90305	2	0.77	4.75

MegaPress Coupling No Stop, Stainless Steel, P x P - Models 4115.5 / 5115.5

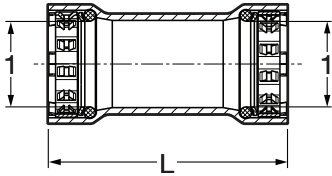

Part No.		Size (in)	L (in)
304	316	1	
95310	90310	1/2	2.71
95315	90315	3/4	2.94
95320	90320	1	3.29
95325	90325	1 1/2	4.63
95330	90330	2	4.74

MegaPress Reducer, Stainless Steel, P x P - Models 4115.2 / 5115.2

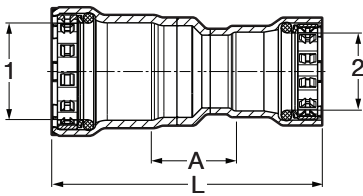

Part No.		Size (in)	A (in)	L (in)
304	316	1 2		
95335	90335	3/4 x 1/2	1.20	3.43
95340	90340	1 x 3/4	1.24	3.74
95345	90345	1 1/2 x 1	1.35	4.57
95350	90350	2 x 1 1/2	1.43	5.26

MegaPress Reducer, Stainless Steel, FTG x P - Models 4115.1 / 5115.1

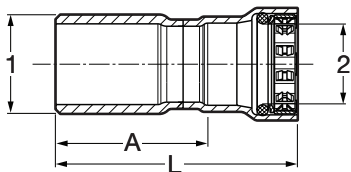

Part No.		Size (in)	A (in)	L (in)
304	316	1 2		
95355	90355	3/4 x 1/2	1.78	2.85
95360	90360	1 x 1/2	2.14	3.21
95365	90365	1 x 3/4	2.09	3.24
95370	90370	1 1/2 x 3/4	2.98	4.13
95375	90375	1 1/2 x 1	2.81	4.16
95380	90380	2 x 1	3.14	4.49
95385	90385	2 x 1 1/2	2.96	4.83

MegaPress Union, Stainless Steel, P x P - Models 4160 / 5160

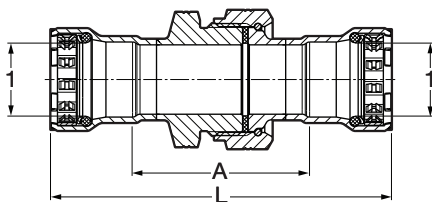

Part No.		Size (in)	A (in)	L (in)
304	316	1		
95415	90415	1/2	2.35	4.50
95420	90420	3/4	2.67	4.99
95425	90425	1	2.65	5.34
95430	90430	1 1/2	2.89	6.63
95435	90435	2	3.92	7.89

MegaPress Flange, Stainless Steel, P x BP - Models 4159.5 / 5159.5

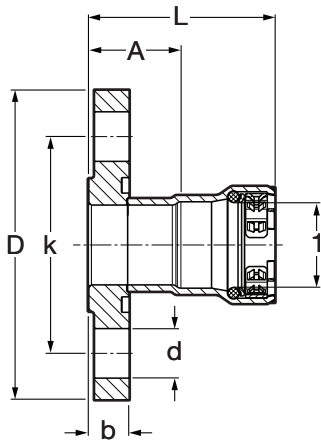

Part No.		Size (in)	A (in)	L (in)	b (in)	k (in)	D (in)	d (in)
304	316	1						
95440	90440	1/2	1.51	2.58	0.46	2.36	3.54	0.63
95445	90445	3/4	1.58	2.74	0.52	2.76	3.94	0.63
95450	90450	1	1.75	3.10	0.58	3.11	4.33	0.63
95455	90455	1 1/2	2.06	3.93	0.70	3.86	4.92	0.63
95460	90460	2	2.07	4.06	0.77	4.76	5.91	0.75

MegaPress Cap, Stainless Steel, P x Cap - Models 4156 / 5156

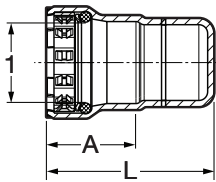

Part No.		Size (in)	A (in)	L (in)
304	316	1		
95390	90390	1/2	1.07	2.14
95395	90395	3/4	1.16	2.26
95400	90400	1	1.35	2.43
95405	90405	1 1/2	1.87	3.02
95410	90410	2	1.99	3.11

Dimensional Documents

MegaPress Stainless 304 2½" to 4" Fittings



This document is subject to updates. For the most current Viega technical literature please visit www.viega.us.



Viega products are designed to be installed by licensed and trained plumbing and mechanical professionals who are familiar with Viega products and their installation. **Installation by non-professionals may void Viega LLC's warranty.**

MegaPress Stainless XL 90° Elbow P x P - Model 4116XL/5116XL

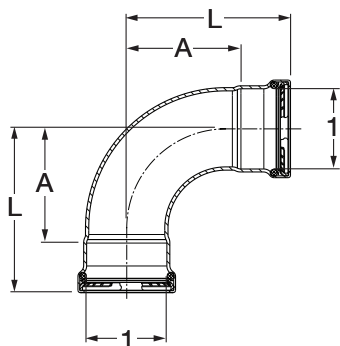

Part Number		Size (in)	A (in)	L (in)
304	316	1		
95500	90500	2½	4.15	5.94
95505	90505	3	4.76	7.09
95510	90510	4	6.00	9.17

MegaPress Stainless XL 90° Street Elbow P x FTG - Model 4116.1XL/5116.1XL

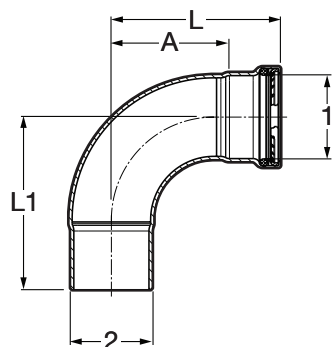

Part Number		Size (in)	A (in)	L (in)	L1 (in)
304	316	1 2			
95515	90515	2½ x 2½	4.15	5.94	6.06
95520	90520	3 x 3	4.76	7.09	6.81
95525	90525	4 x 4	6.00	9.17	8.78

MegaPress Stainless XL 45° Elbow P x P - Model 4126XL/5126XL

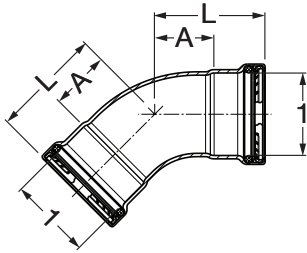

Part Number		Size (in)	A (in)	L (in)
304	316	1		
95530	90530	2½	2.10	3.90
95535	90535	3	2.26	4.56
95540	90540	4	2.74	5.89

MegaPress Stainless XL 45° Street Elbow P x FTG - Model 4126.1XL/5126.1XL

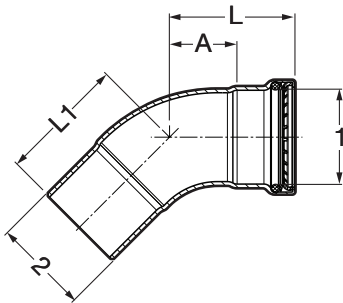

Part Number		Size (in)	A (in)	L (in)	L1 (in)
304	316	1 2			
95545	90545	2½ x 2½	2.10	3.90	3.95
95550	90550	3 x 3	2.26	4.56	4.34
95555	90555	4 x 4	2.74	5.89	5.62

MegaPress Stainless XL Coupling with Stop P x P - Model 4115XL/5115XL

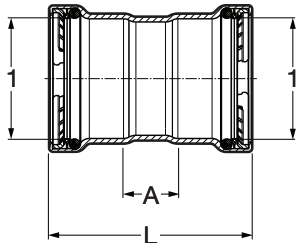

Part Number		Size (in)	A (in)	L (in)
304	316	1		
95645	90645	2½	1.32	4.92
95650	90650	3	1.38	5.98
95655	90655	4	1.57	7.87

MegaPress Stainless XL Coupling No Stop P x P - Model 4115.5XL/5115.5XL

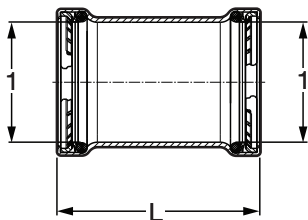

Part Number		Size (in)	L (in)
304	316	1	
95660	90660	2½	4.92
95665	90665	3	5.98
95670	90670	4	7.91

MegaPress Stainless XL Reducer FTG x P - Model 4115.1XL/5115.1XL

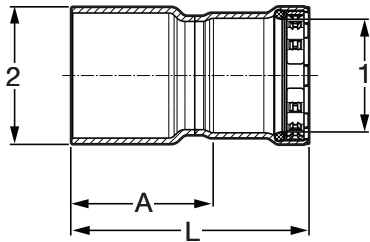

Part Number		Size (in)		A (in)	L (in)
304	316	1	2		
95675	90675	2½	2	2.97	4.96
95680	90680	3	2	3.76	5.75
95685	90685	3	2½	3.75	5.55
95690	90690	4	2	5.28	7.27
95695	90695	4	2½	5.27	7.06
95700	90700	4	3	5.03	7.33

MegaPress Stainless XL Adapter P x MPT - Model 4111XL/5111XL

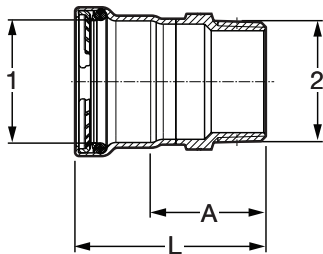

Part Number		Size (in)		A (in)	L (in)
304	316	1	2		
95635	90635	2½	2½	2.75	4.55
95640	90640	3	3	2.89	5.20
95735	90735	4	4	3.03	6.21

MegaPress Stainless XL Adapter P x FPT - Model 4112XL/5112XL

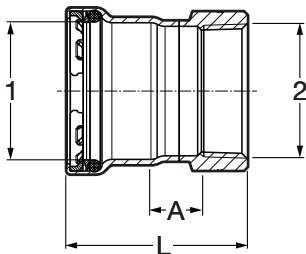

Part Number		Size (in)		A (in)	L (in)
304	316	1	2		
95770	90740	2½	2½	1.13	3.86
95775	90745	3	3	1.17	4.49
95780	90750	4	4	1.15	5.42

MegaPress Stainless XL Tee P x P x P - Model 4118XL/5118XL

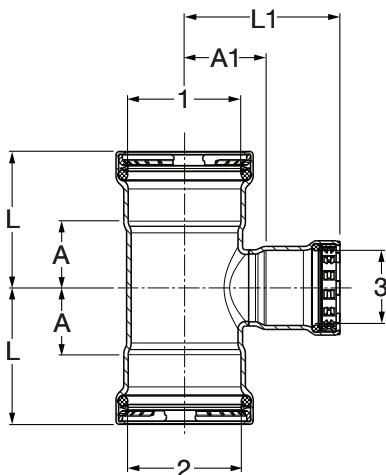

Part Number		Size (in)			A (in)	A1 (in)	L (in)	L1 (in)
304	316	1	2	3				
95575	90575	2½	2½	1½	1.72	2.08	3.52	3.95
95580	90580	2½	2½	2	2.16	2.05	3.96	4.04
95560	90560	2½	2½	2½	2.16	2.26	3.96	4.06
95590	90590	3	3	1½	1.80	2.33	4.13	4.20
95585	90585	3	3	2	2.11	2.30	4.41	4.29
95595	90595	3	3	2½	2.32	2.51	4.63	4.31
95565	90565	3	3	3	2.55	2.52	4.88	4.82
95600	90600	4	4	1½	1.86	2.90	5.04	4.77
95605	90605	4	4	2	2.18	2.87	5.35	4.86
95610	90610	4	4	2½	2.40	3.08	5.55	4.88
95615	90615	4	4	3	2.66	3.13	5.81	5.43
95570	90570	4	4	4	3.22	3.08	6.40	6.26

MegaPress Stainless XL Tee P x P x FPT - Model 4117.2XL/5117.2XL

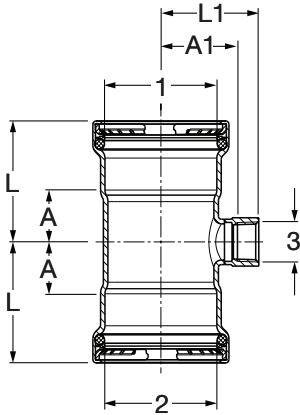

Part Number		Size (in)	A (in)	A1 (in)	L (in)	L1 (in)
304	316	1 2 3				
95620	90620	2½ x 2½ x ¾	1.35	2.00	3.15	2.55
95625	90625	3 x 3 x ¾	1.44	2.24	3.74	2.80
95630	90630	4 x 4 x ¾	1.55	2.76	4.72	3.31

MegaPress Stainless XL Cap P - Model 4156.1XL/5156.1XL

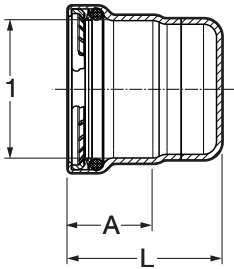

Part Number		Size (in)	A (in)	L (in)
304	316	1		
95705	90705	2½	1.80	3.27
95710	90710	3	2.30	3.82
95715	90715	4	3.18	4.67

MegaPress Stainless XL Adapter Flange P - Model 4159XL/5159XL

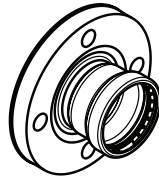
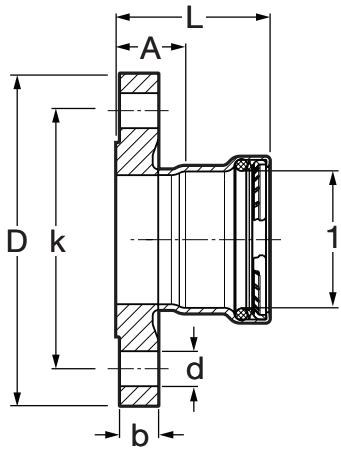

Part Number 304	Part Number 316	Size (in) 1	A (in)	L (in)	b (in)	k (in)	D (in)	d (in)
95720	90720	2½	1.54	3.33	0.89	5.51	7.09	0.75
95725	90725	3	1.65	3.95	0.96	5.98	7.48	0.75

MegaPress Stainless XL Adapter Flange P - Model 4159XL/5159XL

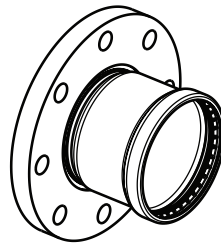
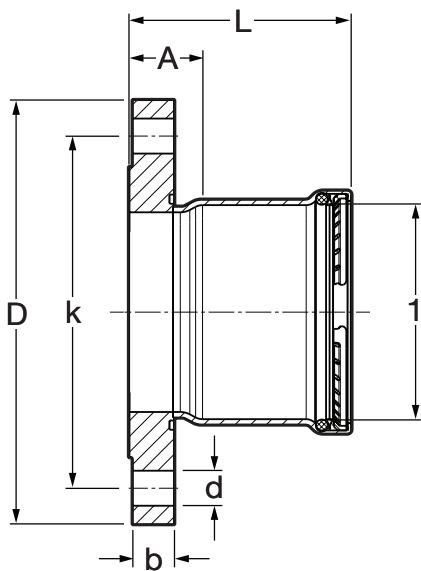

Part Number 304	Part Number 316	Size (in) 1	A (in)	L (in)	b (in)	k (in)	D (in)	d (in)
95730	90730	4	1.63	4.80	0.96	7.52	9.06	0.75

V Viega LLC
585 Interlocken Blvd.
Broomfield, CO 80021

Phone (800) 976-9819
www.viega.us

SM-MP 0519 MegaPress Stainless 304

