

Table of Contents

<u>Section</u>	Page
1.0 Introduction	
1.1 Definitions and Terminology.....	2
1.2 Checklist.....	2
2.0 Operating Sequence and Failure Modes	
2.1 Normal Operating Sequence.....	3
2.2 Component Failure by Conditions.....	4
2.3 Troubleshooting Failure Modes.....	5
2.3.1 V1 Failure Mode.....	5
2.3.2 V2 Failure Mode.....	5
2.3.3 V3 Failure Mode.....	5
2.3.4 V4 Failure Mode.....	5
2.3.5 V5 Failure Mode.....	5
2.3.6 V6 Failure Mode.....	5
3.0 Decommissioning	
3.1 Troubleshooting and Repair Warning Statement.....	6
3.2 Decommissioning the Unit for Troubleshooting.....	6
3.3 Decommissioning the Unit for Repairs.....	6
3.4 Decommissioning Images.....	7
4.0 Adjustments and Repairs	
4.1 V1 Mixing Valve.....	8
4.2 V2 Capillary Valve.....	9
4.3 V3 Diaphragm Valve.....	9
4.4 V4 Control Valve.....	10
4.5 V5 Tempering Valve.....	11
4.6 V6 Valve.....	11
4.7 TV/HAT 155°F.....	11
5.0 Heat Exchanger Cleaning.....	11
<u>Appendices</u>	Page
Appendix #1: Station Schematic.....	12
Appendix #2: Station Operating Logic Flow Chart.....	13
Appendix #3: Typical Installation Schematic.....	14
Appendix #4: Labeled Station Line Drawing.....	15
Appendix #5: Hoses and Hose Fittings Line Drawing.....	16
Appendix #6: Clean In-Place Instructions.....	17

Section 1.0: Introduction

This manual is designed to aid qualified personnel in troubleshooting and repairing of the Therm-O-Mix® Station. **Qualified personnel assigned to troubleshoot or repair a Therm-O-Mix® Station should read the entire manual before proceeding.** If you have any questions or concerns about the information found in this manual, please contact ThermOmegaTech® at 1-877-379-8258.

Section 1.1: Definitions and Terminology

- System = safety shower/eyewash station
- Heater = Therm-O-Mix® Station tempered water unit
- Normal Range = tepid/moderately warm/lukewarm not to exceed 100F
- Flow Pressure = gauge pressure measured during flow (dynamic pressure)
- HtEx = stainless steel brazed plate heat exchanger
- V1 = primary mixing valve; mixes cold inlet water with heated water from V5
- V2 = normally open; controls hot water temperature out of HtEx by regulating steam flow into HtEx
- V3 = normally closed; pressure sensing diaphragm valve; opens in response to pressure differential across unit, allowing steam flow to HtEx
- V4 = normally closed; senses water temp out of mixing valve V1; V4 will open if the water temperature is too high, short circuiting pressure differential across diaphragm, closing V3 and turning steam flow off
- V5 = normally open; pre-mixes cold water with hot water from heat exchanger prior to mix entering the V1 mixing valve.
- V6 = normally closed; starts to open when water temp at valve approaches 95F due to heat soak or heat migration.

Section 1.2: Checklist

Review the below checklist before troubleshooting.

- Does the plant have adequate Steam Flow Pressure for the selected Therm-O-Mix® Station?
 - Standard Pressure Steam Heater - Requires min. 45 PSIG/max. 60 PSIG. Above 60 PSIG requires pressure regulator. Above 75 PSIG requires pressure regulator and relief valve.
 - Lower Pressure Steam (LPS) Heater - Requires min. 15 PSIG/max. 30 PSIG. Above 30 PSIG requires pressure regulator. Above 45 PSIG requires pressure regulator and relief valve.
- Is the station's steam supply line properly sized? (Recommended min. 1" IPS)
- Does the plant have adequate Water Flow Pressure? (min. 55 PSIG while flowing 25 GPM.)
- Is the station's water supply line properly sized? (Recommended min. 1-1/4" IPS)
- Is the station's supplying tepid water to anything other than the Safety Shower Station?
NOTE: Water flow from heater must be dedicated to safety shower/eyewash.
- Are freeze and scald protection valves installed correctly?
- Is the water supply line in contact with or being overheated by another source?
- Is the condensate properly sized? Is the condensate blocked?

Section 2.0: Operating Sequence and Failure Modes

Section 2.1: Normal Operating Sequence

1. Activating the shower or eyewash station initiates cold water flow, resulting in a pressure drop in the V3 Diaphragm and across the unit.
2. Cold water inlet tee directs flow to HtEx, V5 pre-mixing valve, and V1 mixing valve.
3. Steam heats cold water in the HtEx. V2 modulates steam flow based on water temperature from HtEx.
4. Hot water from HtEx enters V5 pre-mixing valve, and mixes with cold inlet water.
5. The hot water enters V1 mixing valve and mixes with more cold inlet water, producing 80°F water to supply the system.

(Refer to below diagram, Appendix #1 for Station Schematic, and Appendix #2 for Station Operation Flow Chart.)

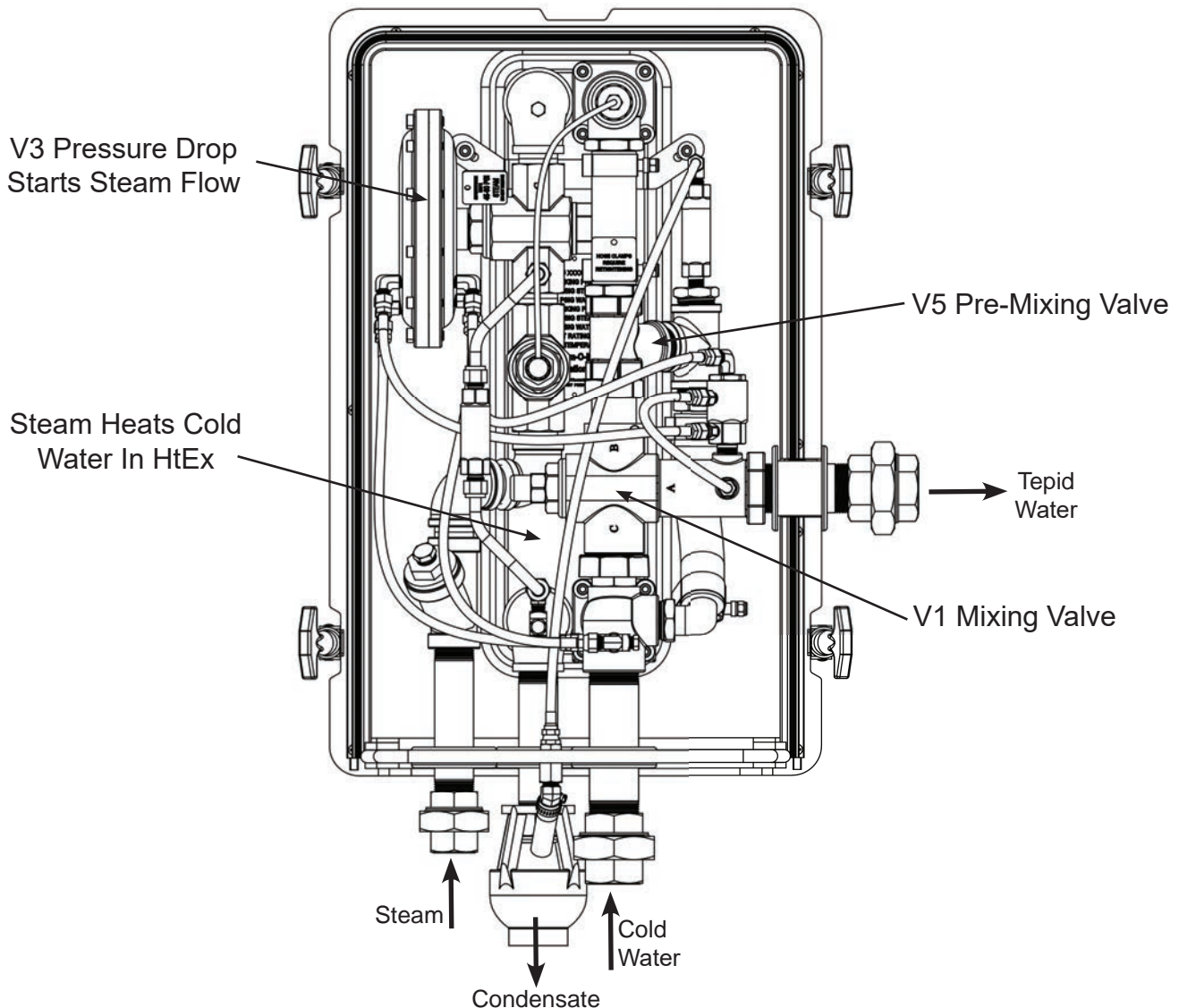

Section 2.2: Component Failure by Conditions

CONDITION		COMPONENT FAILURE
If steam is coming out of the drain line while at idle. ** Note: Some water vapor/condensate is normal.		Confirm V3 is in closed position. Remove brass pipe plug from reducing tee directly above the V3 diaphragm valve. Slowly open the steam supply valve to see if steam flows past the V3 seat seal into the reducing tee. If steam is present, V3 and the valve body seal need to be repaired or replaced (<i>Section 4.3</i>). If steam is not present the TV/HAT 155 needs to be replaced. (<i>Section 4.7</i>)
If the outlet temperature remains above the normal range for long periods of time without fluctuation in the outlet temperature.		Follow Section 4.1 to check or replace V1 mixing valve. Check V4 control valve and replace if not functioning correctly.
If the outlet temperature fluctuates, rising above dropping below the normal range.		Follow Section 4.1 to check and/or adjust V1 mixing valve. If it cannot be adjusted, replace V1.
If the eyewash is running in the normal range, but the shower runs below the normal range.		The V2 Capillary Valve needs to be adjusted. (<i>See Section 4.2</i>)
If the eyewash runs above the normal range, but the shower runs in the normal range. **Note: Steam will probably be coming out of the drain line while running the eyewash.		The V2 Capillary Valve needs to be adjusted (<i>See Section 4.2</i>). If the valve cannot be adjusted correctly a replacement V2 Capillary is required.
If there is a constant flow of warm water flowing through drain line.		V-6 has failed open. (<i>See Section 4.6</i>)
If there is an momentary temperature spike over 100 °F when flow begins.		V-6 has failed closed. (<i>See Section 4.6</i>)
Cold Water Only	If the V3 does not open allowing steam to pass to the heat exchanger. **Note: Check to see if the V3 indicator does not move.	Inspect V3 to make sure it is not jammed (<i>See Section 4.3</i>). Remove the V4 Control valve for testing. (<i>See section 4.4</i>)
	V3 opens approximately .300in., V1 is properly adjusted (<i>See Section 4.1</i>), V2 is open	Verify that steam is present at the Heater. Remove the Y-strainer cap and check the screen for debris. If the Heater is still not producing tepid water the heat exchanger may be clogged with minerals. The Heater can be flushed in place or removed and flushed with the proper equipment. If the proper equipment is not available the unit can be returned to the factory for flushing and recalibration.
	V5 does not allow water to pass through V1	Verify that the hot water line above V5 is hot and hot side inlet to V1 is cold during operation. Either the actuator has failed or cold water is blocked.

Section 2.3: Troubleshooting Failure Modes

Note: Prior to starting any troubleshooting, look to see what is visible before activating water flow. (Any leaks? Excess water or steam vapors from drain line? Any visible damage?)

Section 2.3.1: V1 Failure Mode

If V1 failed with cold port closed (hot port open): hot water from outlet of HtEx flows to V5 premix valve where hot inlet to V1 is combined with cold water to about 105F. This triggers V4 to close V3 so no steam flows to HtEx and only cold water flows to shower/eyewash.

If V1 failed with hot port closed (cold port open): cold water into V1 flows to shower/eyewash.

Section 2.3.2: V2 Failure Mode

If V2 fails open: loss of steam flow control to HtEx. Full steam flow at all water temps. If V1 is functional, it will proportion hot and cold-water flow to maintain 80°F output to system. If V4 is functional, it will turn off V3 if output from V1 is too high. (Excess steam will escape through drain line.)

If V2 fails closed: no steam flow to HtEx; unit flows only cold water to system. Water outlet tee is cold to the touch. Debris may be causing the steam valve to stay closed. At low flow the outlet temperature will be about 80°F, at high flow the outlet temperature is below the required temperature.

Section 2.3.3: V3 Failure Mode

If V3 failed closed: no steam flow to HtEx; unit will output cold water; V3 indicator will not move.

If V3 fails open: steam flow to HtEx is always on. V2 controls temp of hot water out of HtEx. V1 mixes hot and cold water to control 80°F output; assume V4 cannot close V3, so V4 has no effect. Steam will leak from the drain line even when the shower/eyewash unit is not activated. Large water leaks (over 1 GPM) down stream would produce lower water pressure on the lower diaphragm housing, possibly opening V3. Debris may be stuck in sealing area or V3 may be jammed open.

Section 2.3.4: V4 Failure Mode

If V4 failed closed: no significance unless V1 also fails. Output temperature is over 95°F for more than 15 sec.

If V4 failed open: steam will not turn on, so only cold water flows from the Heater. V3 may open during the shower operation and allow steam to pass, but V3 will not open during eyewash operation. Debris may be stuck to the seat area inside the V4 not allowing a good seal.

Section 2.3.5: V5 Failure Mode

Hot port closed: only cold water would be supplied to V1 and unit will output cold water.

Cold side port blocked: hot side will shut itself off, not supplying V1 at all and would produce supply water temperature. Cold side port is not regulated so only a blockage can cause cold side port to close water flow

Section 2.3.6: V6 Failure Mode

Valve failed closed: outlet water temperature “spike” to slightly over 100F for a couple of seconds.

Valve failed open: increased water discharge into drain connection.

Section 3.0: Decommissioning

Section 3.1: Troubleshooting and Repair Warning Statement

Troubleshooting in the field requires turning off the water and steam supply to the emergency safety shower/eyewash system. Contact the plant safety manager/supervisor and follow proper procedures for temporarily rendering the safety equipment unusable. Notify all personnel working in the area that the emergency safety shower/eyewash equipment will be temporarily disabled.

*****WARNING: PIPING MAY BE HOT AND HOT WATER
MAY BE TRAPPED IN THE HEATER.**

Section 3.2: Decommissioning The Unit for Troubleshooting

1. Close the unit's steam supply valve.
2. Activate the shower and eyewash system for a minimum of two minutes to deplete the steam pressure trapped between the steam supply shutoff valve and the unit.
3. To remove the yellow enclosure, face the unit with outlet connection on your right. Un-clip the side clamps and pull the bottom of the front cover towards you. The back cover is attached to the heat exchanger by a stainless bracket and end bolts.
4. Once trouble shooting is complete, turn the steam supply on and activate the shower for at least one minute to purge the system.
5. Insert the temperature-reading device into the eyewash nozzle. Activate the eyewash and record the temperature several times over a 5-10 minute cycle. Note movement of V3 indicator and o-ring on the V2 capillary valve. Repeat this step for the shower, attaching the temperature-reading device to the shower-head. Record temperatures, V3 indicator, and capillary valve movement.

Section 3.3: Decommissioning The Unit for Repairs

1. Close the unit's steam supply valve.
2. Activate the shower and eyewash system for a minimum of two minutes to deplete the steam pressure trapped between the steam supply shutoff valve and the unit.
3. With the system activated, closer the water supply valve to the unit.
4. To remove the yellow enclosure, face the unit with outlet connection on your right. Un-clip the side clamps. Pull the bottom of the front cover towards you. The back cover is attached to the heat exchanger by a stainless bracket and end bolts.
5. Repair or replace components as needed.
6. Open the water supply valve to the Heater. Once water is flowing open the steam valve slowly. Allow he unit to run for at least one minute to purge the system.
7. Insert the temperature-reading device into the eyewash nozzle. Activate the eyewash and record the temperature several times over a 5-10 minute cycle. Note movement of V3 indicator and o-ring on the V2 capillary valve. Repeat this step for the shower, attaching the temperature-reading device to the shower-head. Record temperatures, V3 indicator, and capillary valve movement.
8. Once the Heater is operating correctly close the steam supply line to the Heater.
9. Activate the shower and eyewash system for a minimum of two minutes to deplete the steam pressure trapped between the steam supply shutoff valve and the Heater.
10. Turn the steam supply back on and activate the shower for at least one minute.
11. Replace and secure the yellow enclosure.

Section 3.4: Decommissioning Images

V3 Indicator

Open Position



Closed Position



V2 Capillary Valve O-Ring

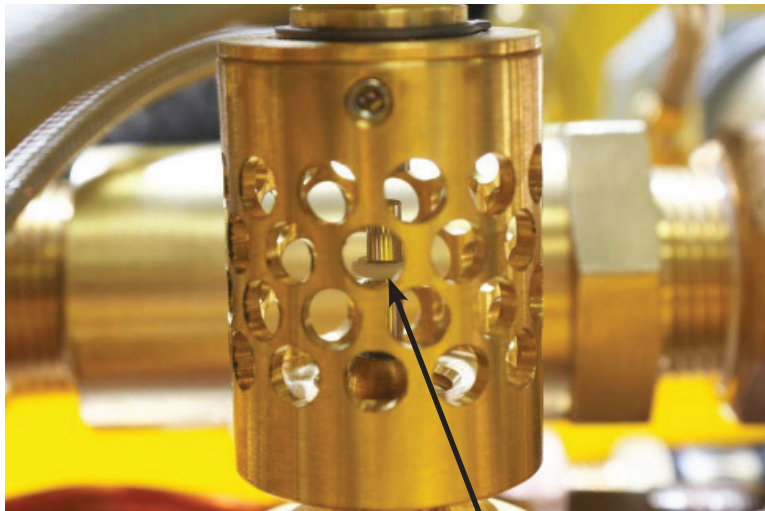

O-Ring
Indicator

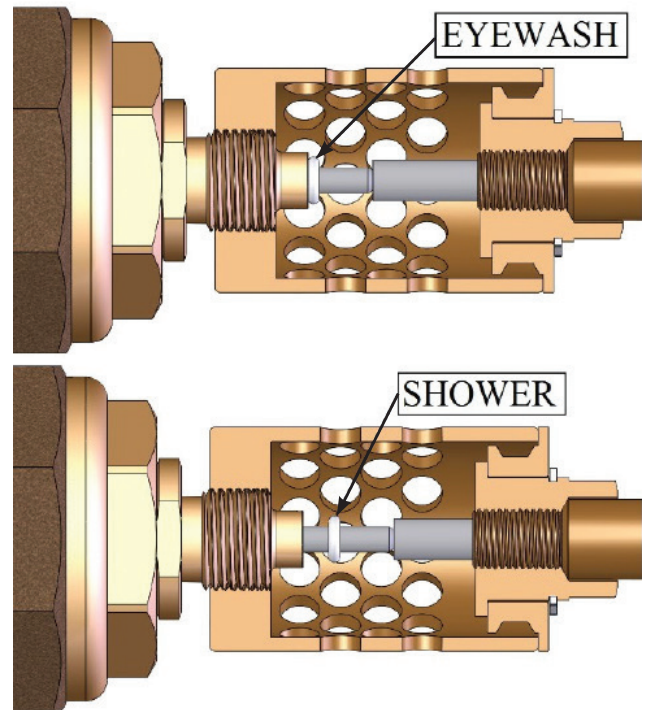

Section 4.0: Adjustments and Repairs

Prior to beginning any repairs, follow all steps in section 3.3 to decommission the station. Test the unit after all repairs have been completed to confirm full functionality.

Section 4.1: V1 Mixing Valve

V1 Mixing Valve Adjustment Outside of the Unit

1. Unscrew entire main valve cap from V1 mixing valve with a 1-1/2" wrench. The entire internal assembly will pull out of the valve body in one piece.
2. Remove mixing valve cap nut with 1" wrench.
3. Loosen calibration lock nut with a 7/16" wrench.
4. Place valve into a 90°F water bath for five minutes.
5. Use calibration screw to adjust the valve spool so that the inner spool cold water slots line up with outer housing cold water slots so that cold side is fully open and hot side is fully closed. Place valve into an 80°F water bath for five minutes.
6. Use calibration screw to adjust the valve spool so that the inner spool hot water slots line up with outer housing hot water slots so that hot side is fully open and cold side is fully closed.
7. Tighten the calibration jam nut.
8. Screw the mixing valve assembly back into the V1 mixing valve body.

V1 Mixing Valve Internal Assembly Replacement

Follow instructions provided with replacement part from ThermOmegaTech®

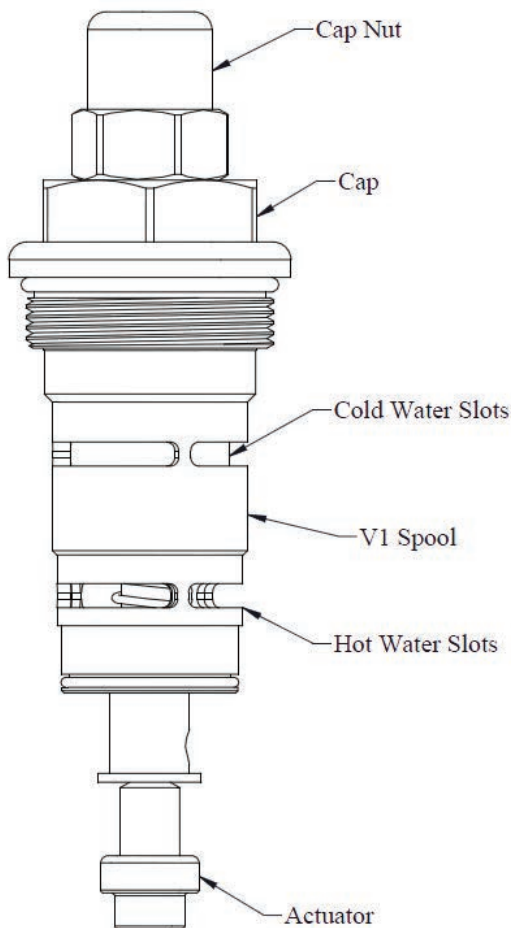

Remove Cap Screw



Remove Lock Nut



Adjust Calibration Screw

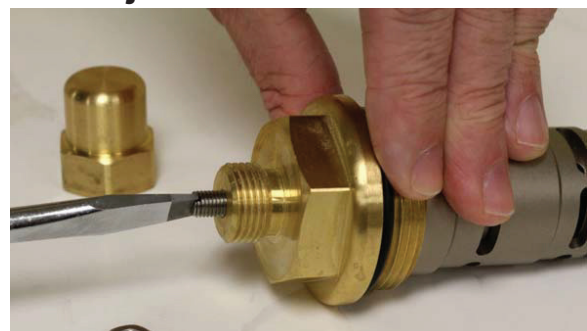

Section 4.2: V2 Capillary Valve

V2 Capillary Valve Adjustment

1. On the end of the heat dissipater nearest V2 valve body, there are four setscrews holding the perforated heat dissipater to the valve. One of the four setscrews are substantially recessed and only this one should be loosened. Newer units will only have the one locking setscrew located closest to the V-2 valve.
2. After loosening the locking setscrew, turning the heat dissipater housing clockwise will lower the hot water outlet temperature from the heat exchanger and also the water temperature from the shower/eyewash. Turning the heat dissipater counterclockwise will raise the water temperature. Rotate the heat dissipater a half turn at a time. Re-run the system after each adjustment.
3. Lock the setscrew on heat dissipater when finished.

V2 Capillary Valve Replacement

Follow instructions provided with replacement part from ThermOmegaTech®



Section 4.3: V3 Diaphragm Valve

V3 Diaphragm Valve Test

1. To check the diaphragm for leaks plug one of the outside angle hose adapters and slowly apply no more than 20-PSI air pressure to the other outside angle adapter. With the air pressure applied to the adapter the seal holder should move off of the seat. When the pressure is released the seal holder should move back. If air is continuously flowing out of the inside angle hose adapters than there is a hold in the diaphragm. If the Diaphragm Valve is not working correctly a replacement V3 is required.

V3 Diaphragm Valve Seal Replacement

Follow instructions provided with replacement part from ThermOmegaTech®

V3 Diaphragm Valve Replacement

Follow instructions provided with replacement part from ThermOmegaTech®

Section 4.4: V4 Control Valve

V4 Control Valve Test

1. Place V4 valve into a water bath at 98°F or above for five minutes.
2. If you blow compressed air into the upper angled hose adapter the valve should be closed.
3. Place V4 into a water bath at 85°F or below for five minutes.
4. If you blow compressed air into the lower straight hose adapter it should be closed.
5. If the valve does not work correctly a replacement V4 Control Valve is required.

V4 Control Valve Replacement

Follow instructions provided with replacement part from ThermOmegaTech®

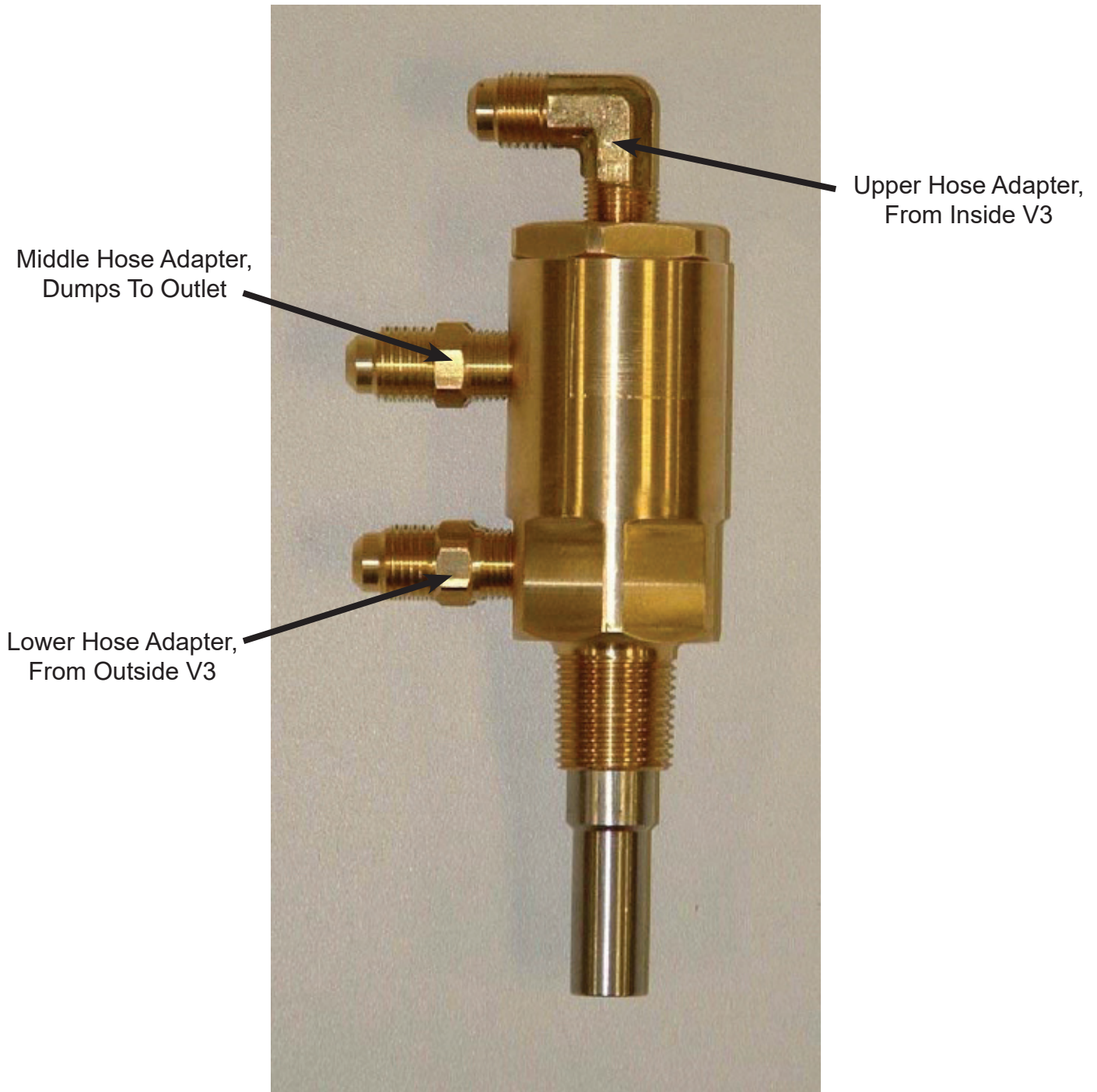

Section 4.5: V5 Tempering Valve

V5 Tempering Valve Test

1. If section 2.2 indicates V5 valve failure, decommission unit and replace V5 valve.

V5 Tempering Valve Replacement

Follow instructions provided with replacement part from ThermOmegaTech®

Section 4.6: V6 Valve

V6 Valve Test

1. If section 2.2 indicates V6 valve failure, decommission unit and replace V6 valve.

V6 Valve Replacement

Follow instructions provided with replacement part from ThermOmegaTech®

Section 4.7: TV/HAT 155°F

TV/HAT 155°F Valve Test

1. If section 2.2 indicates TV/HAT 155°F failure, decommission unit and replace TV/HAT155°F valve.

TV/HAT 155°F Valve Replacement

Follow instructions provided with replacement part from ThermOmegaTech®

Section 5.0: Heat Exchanger Cleaning

The Heater's heat exchanger and capillary sensor may become clogged/coated with mineral deposits over time and require cleaning with de-scaling solvents. Cleaning solution must be compatible with copper alloys, EPDM, Stainless Steel, PTFE, and Buna-N O-rings. (*Recommended manufacturer: Armstrong's Clean-In-Place Scale Removal System*)

Unit can be cleaned while installed or disconnected at the unions and cleaned at another location. Cleaning the unit while installed requires additional fittings (*See Appendix #6*). Tee fittings should be installed on the water inlet supply line upstream from the inlet union and on the tepid water outlet line downstream of the outlet union. Four locking ball valves will be needed to isolate the unit from the plant water supply during cleaning. The first ball valve should be installed upstream of the inlet tee, the second installed on the leg of the inlet tee, the third installed downstream of the outlet tee, and the last installed on the leg of the outlet tee where the cleaning system will be connected.

NOTE: Inlet and outlet layout may differ, depending on station version.

Pump solution into normal flow direction, check valves will prevent reverse flow. Cleaning solution must remain below 80°F. The cleaning time needed depends on local water conditions and frequency of cleaning. After the solution is drained, flush unit with potable water for 15 minutes to prevent contamination. If the unit was cleaned while installed, complete the flush before opening the isolation ball valves. Close the two ball valves on the legs of the tee and open the downstream ball valve first. Activate the shower/eyewash then open the upstream ball valve and allow the system to run for several minutes. Open the steam supply valve and check the water outlet temperatures.

Appendix #1: Station Schematic

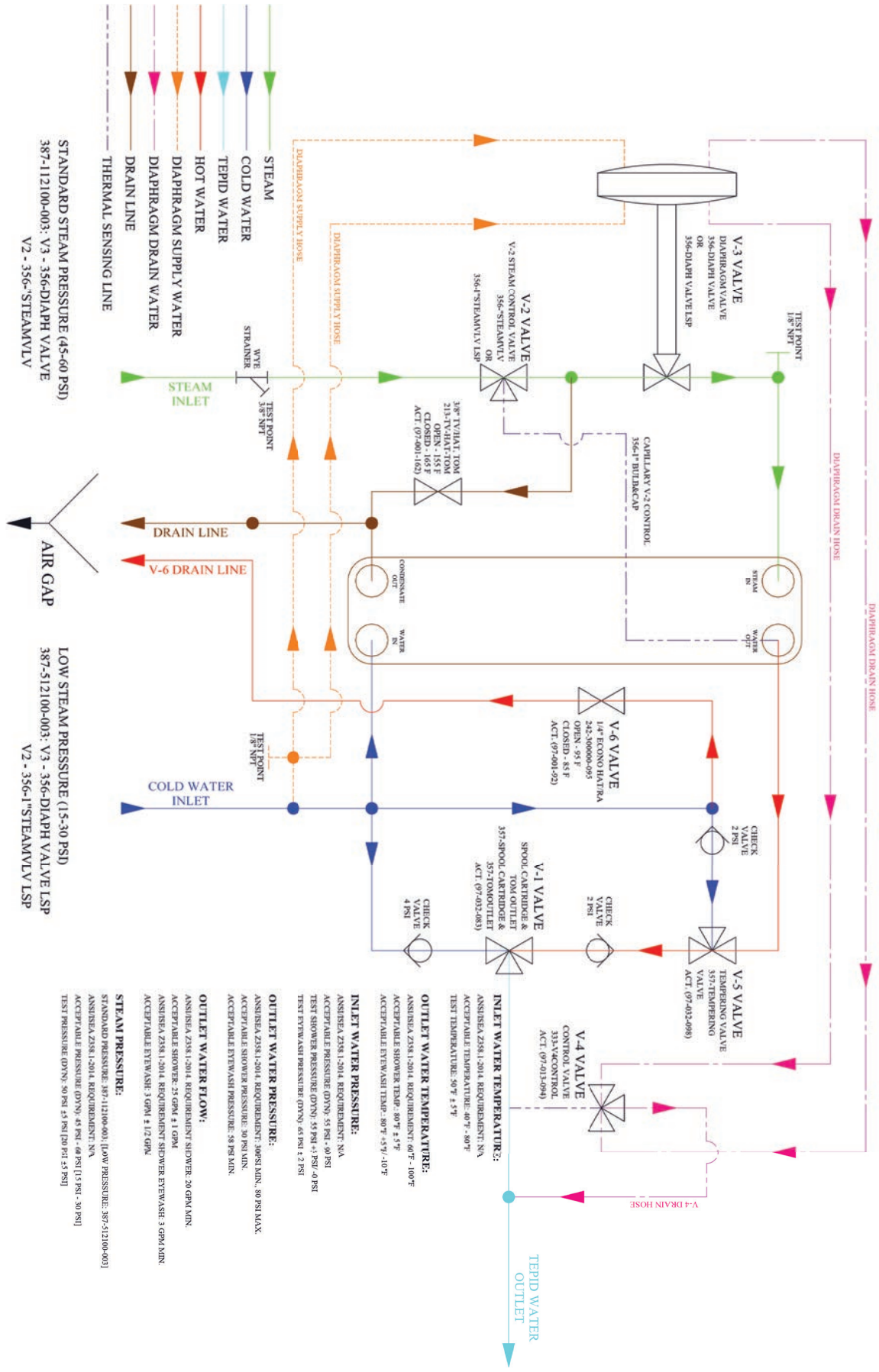

Appendix #2: Station Operating Logic Flow Chart

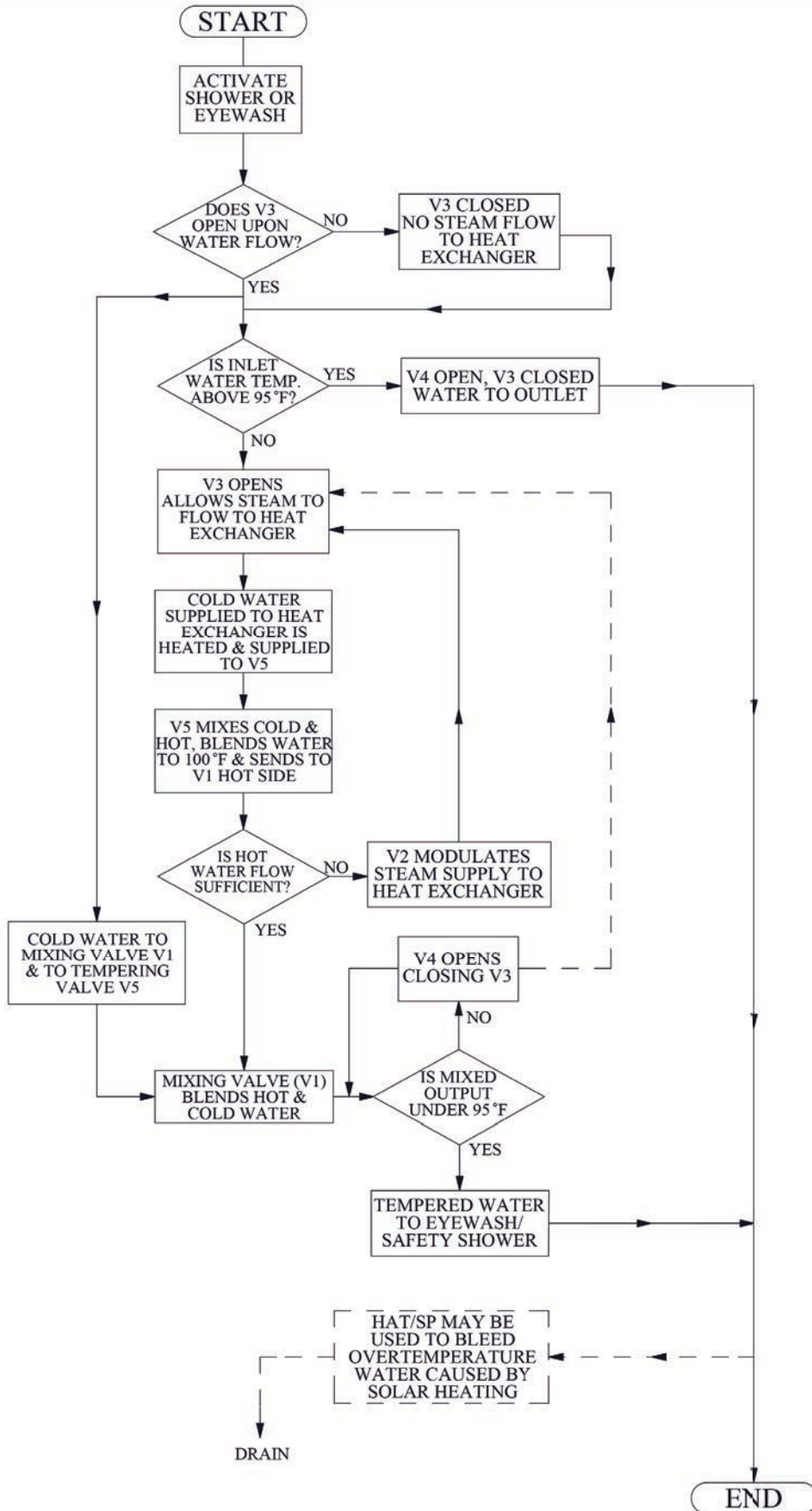

Appendix #3: Typical Installation Schematic

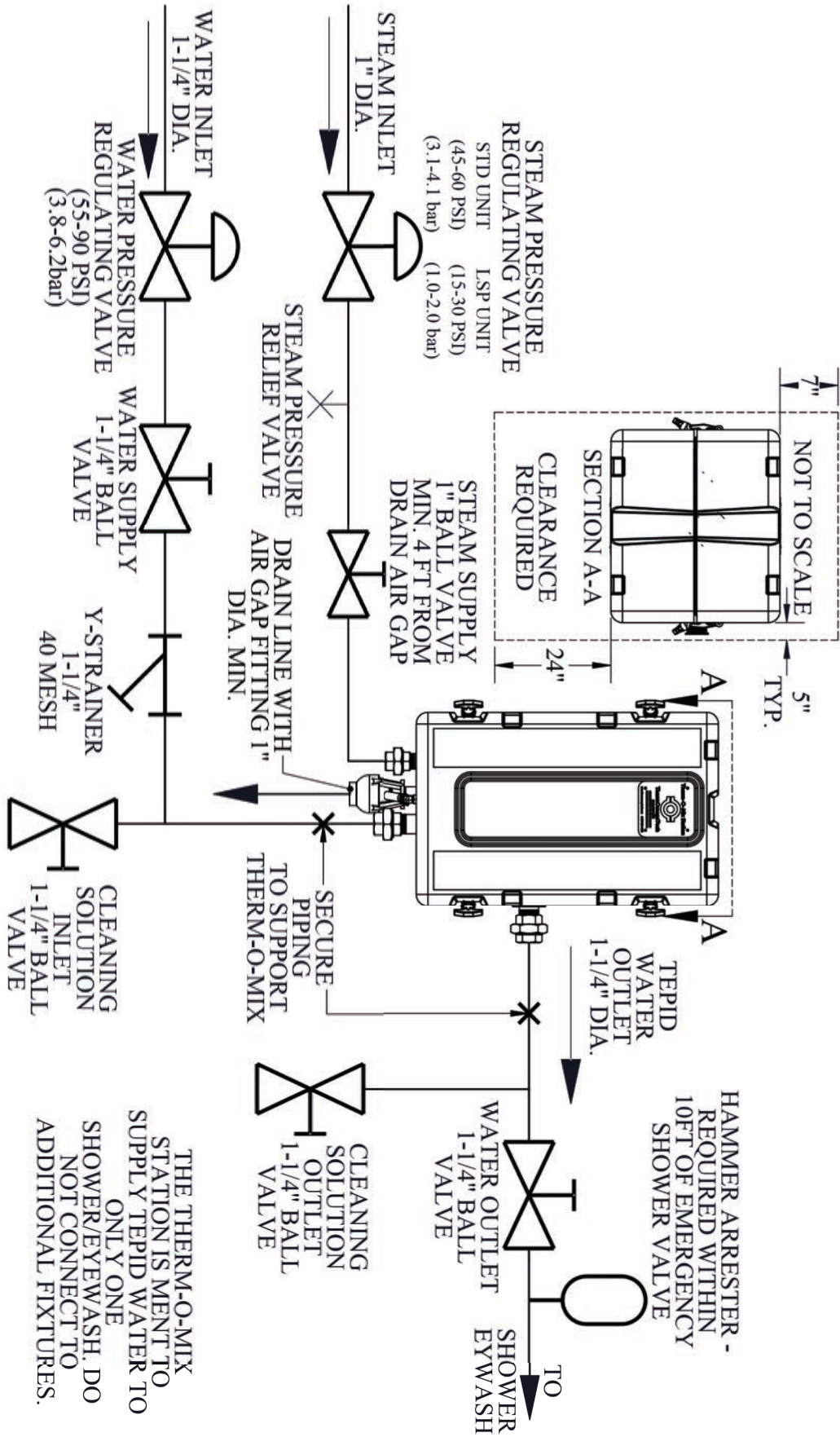

Appendix #4: Labeled Station Line Drawing

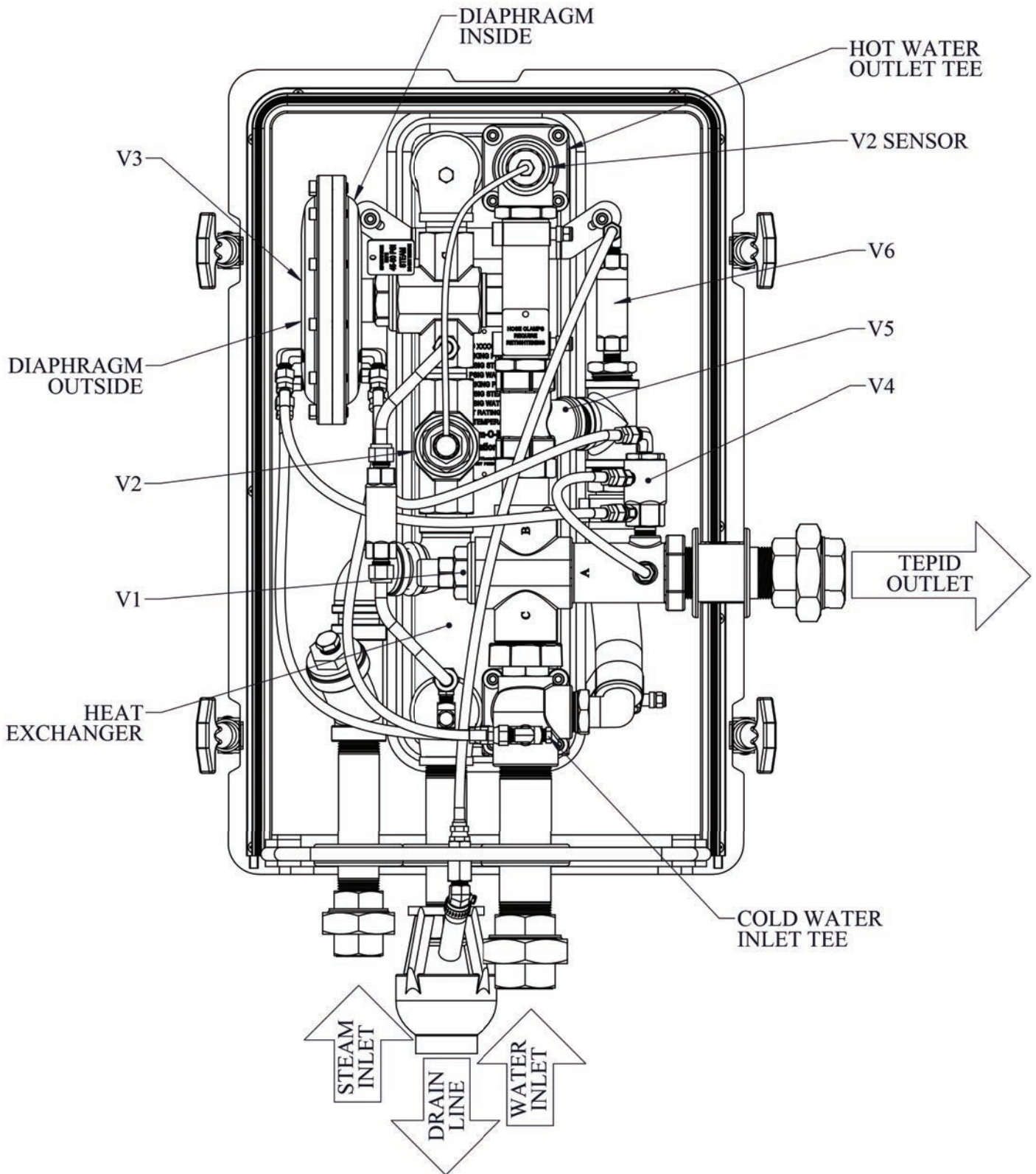

Appendix #5: Hoses and Hose Fittings Line Drawing

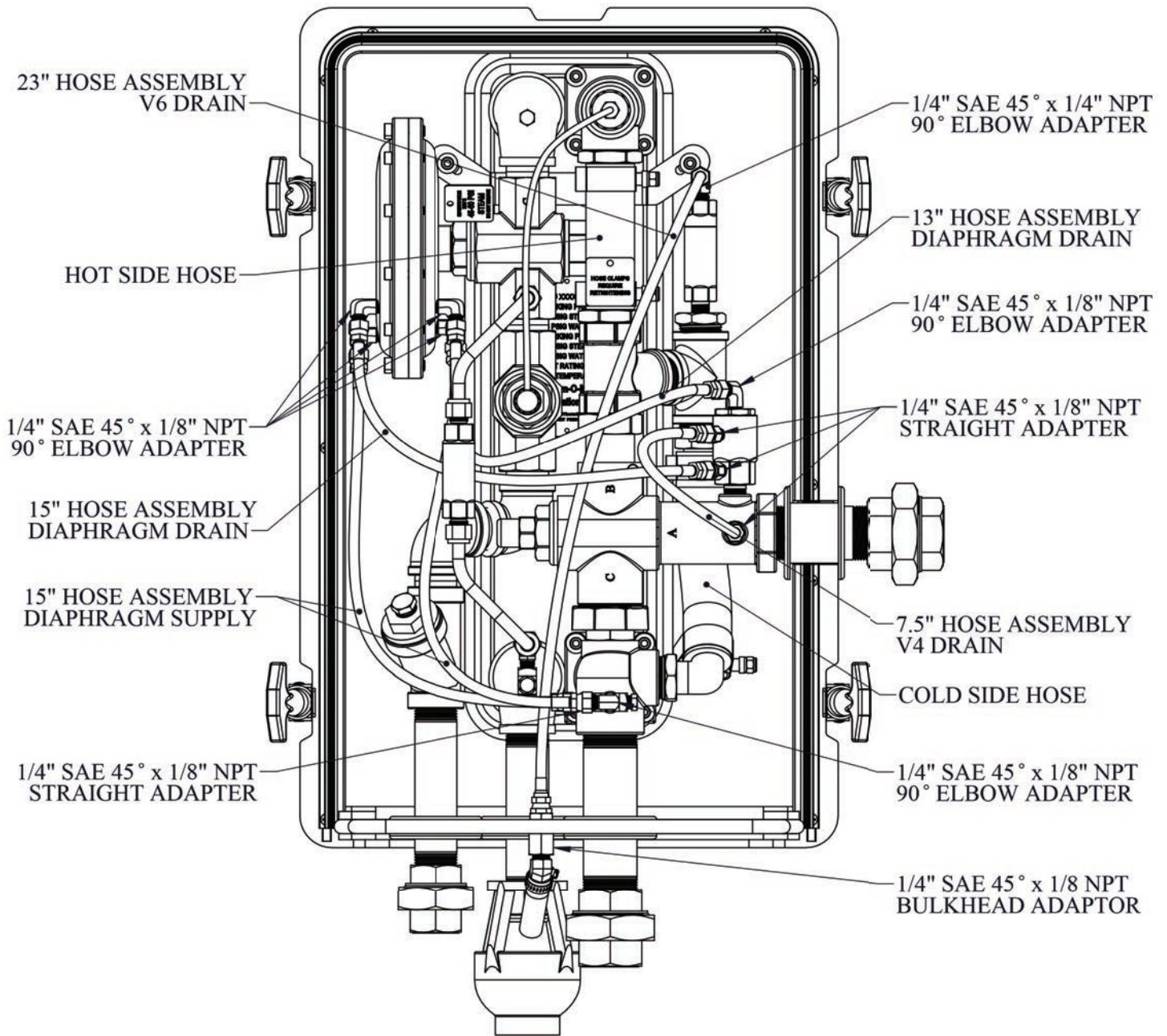

Appendix #6: Clean In-Place Instructions

Therm-O-Mix Station Clean-In-Place Instructions

1. Verify that the cleaning solution inlet and outlet ball valves have been installed in the correct locations as seen in the diagram below.
2. Close the steam supply line valve to the Heater.
3. Activate the shower and eyewash system for a minimum of two minutes to deplete the steam pressure trapped between the steam supply shutoff valve and the Heater. A longer period of time may be needed, depending on the size and length of supply piping.
4. With the system activated close the water supply valve to the Heater.
CAUTION: THERM-O-MIX® STEAM WATER HEATER PIPING MAY BE HOT AND CARE SHOULD BE TAKEN DURING REPAIRS. BE CAREFUL WHEN REMOVING PARTS FOR REPAIR OR REPLACEMENT: HOT WATER MAY BE TRAPPED IN THE HEATER.
5. Close the water outlet ball valve and open the cleaning solution ball valves.
6. Connect the Clean-In-Place system (see NOTE 1) discharge hose to the cleaning solution inlet ball valve. Connect the Clean-In-Place system return hose to the cleaning solution outlet ball valve. The flow of cleaning solution must be in the same direction as water flow due to the Therm-O-Mix internal check valves.
7. Turn on the Clean-In-Place pump to cycle cleaning solution through the Heater. Cleaning time will depend on the local water conditions and frequency of cleaning. (see NOTE 2 for cleaning solution information)
8. After cleaning solution is drained, the Heater should be flushed with potable water for 5-10 minutes before opening the water supply and water outlet ball valves to prevent contamination.
9. Close both the cleaning solution ball valves. Open the water outlet ball valve.
10. Open the water supply valve to the Heater. Once water is flowing, open the steam valve slowly. Allow the Heater to run for at least minute to purge the system of air and any cleaning solution. Check water outlet temperatures.

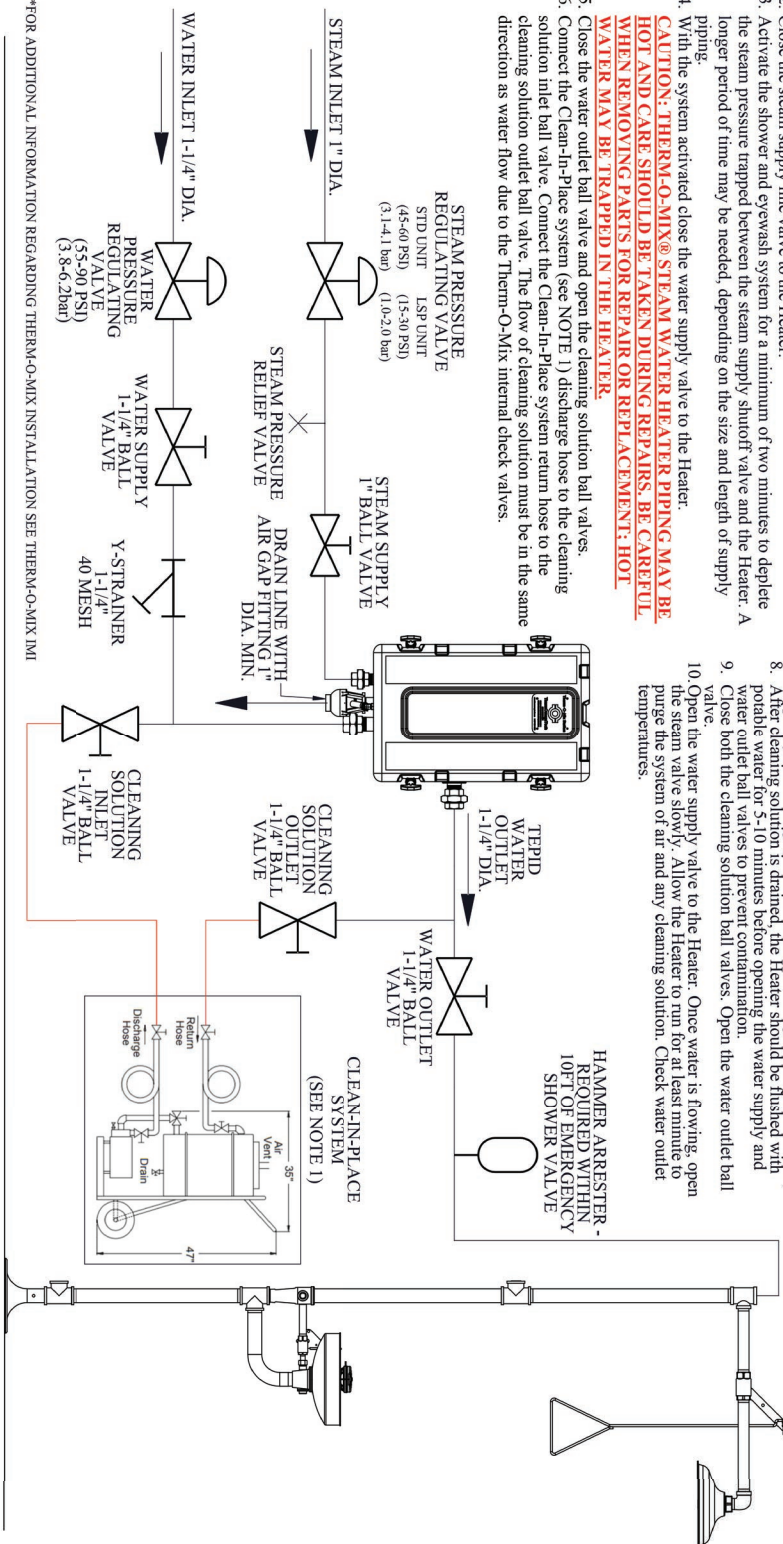

*FOR ADDITIONAL INFORMATION REGARDING THERM-O-MIX INSTALLATION SEE THERM-O-MIX IMI

NOTE 1: ThermOmegaTech recommends using the Armstrong Clean-In-Place system.

NOTE 2: Contact Clean-In-Place manufacturer for proper cleaning solution. Cleaning solution must be compatible with the following materials: SS, Brass, EPDM rubber, Buna rubber, and PTFE.

OTHER TRADES REQUIRED	ISO	SHEET	DRAWN BY	CHECK BY	SCALE	REV	DATE
XXXXX-XXXX-XXXX-XXXX	9001	TITLE	THERM-O-MIX STATION CLEAN-IN-PLACE	INSTRUCTIONS			
XXXXXXXXXXXX	REV	NUMBER	387-X12X00-00X-CLEAN-IN-PLACE				

WARNING: This product can expose you to chemicals, for example lead, nickel, acrylonitrile, which are known to the State of CA to cause cancer, birth defects, or reproductive harm. For more information, go to www.P65Warnings.ca.gov