



# Mixing and Diverting



**ThermOmegaTech®'s mixing & diverting valves are designed with advanced thermal actuator technology to accurately proportion flow in response to temperature in a variety of industrial applications.**

**ThermOmegaTech's QMS is certified to the AS9100 D Standards**

**[www.ThermOmegaTech.com](http://www.ThermOmegaTech.com)  
877-379-8258**

## 3-Way Mixing & Diverting Valves

ThermOmegaTech®'s M/D temperature control valves are designed for 3-way mixing or diverting applications. Utilizing our exclusive Thermoloid® sensor/controller, M/D valves automatically and accurately proportions flow in response to fluid temperature. Reactive, compact, and low mass, the Thermoloid® sensor/controller is the most advanced and reliable thermal actuator of its type available today.

These valves act as thermal bypass valves (TBVs) to modulate fluid temperature as they divert return flow through a cooler/ heat exchanger or bypass it to a reservoir/ bypass loop when fluid temperatures are satisfied. This action assures rapid system warm-up, accurate control of fluid temperature, and reduced back pressure in the return. They can also operate as mixing valves by adjusting the flow through ports "B" and "C" to provide the desired temperature exiting the "A" port.

### Thermal Bypassing

The TBV cartridge can be integrated into a 4-way manifold to monitor inlet flow and divert the fluid based on temperature. Cooler fluid goes through the valve bypass, while hotter fluid goes through the system's cooler.

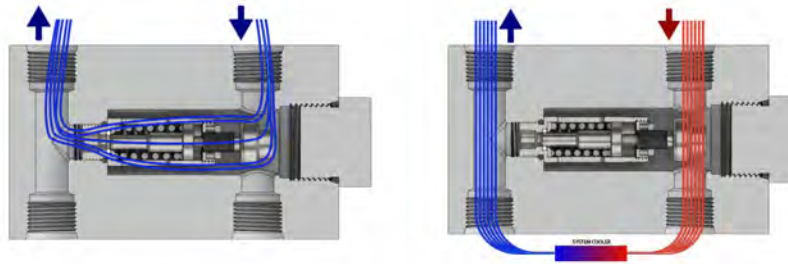

### Thermal Mixing

In **mixing applications** where controlled temperature outlet is required, the mixing valve's thermal actuator will automatically proportion the flow of hot and cold fluid from two inlet ports to produce the desired outlet port temperature.

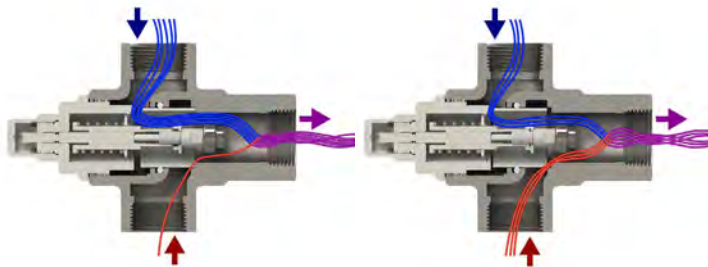

### Thermal Diverting

In **diverting applications** where fluid must be directed from one section of a system to another, the thermal actuator of the thermostatic diverter will automatically divert or switch the inlet flow to either of the two outlet ports depending on fluid temperature.

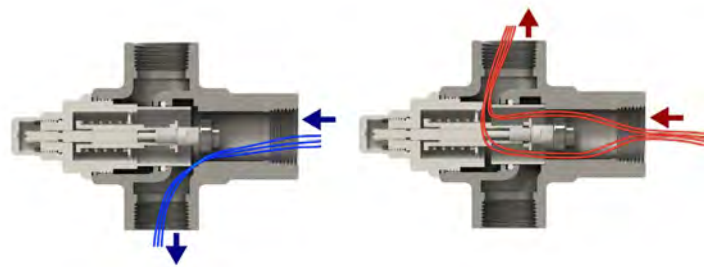

## Typical Applications

- Cooling water control - radiator
- Cooling water control - heat exchanger
- Hydraulic fluid cooling systems
- Direct cooling with raw water
- Lube oil cooling control
- Constant temperature bath, wash basins & sinks
- Loop-type circulation systems
- Direct injection water heating
- Hot water washdown stations
- Make-up water
- Electric system cooling
- Air conditioning
- Water conservation

For product dimensions, specifications, and customizations, visit [www.ThermOmegaTech.com](http://www.ThermOmegaTech.com)

## Sample Applications

### Cooling Water Control Using Radiator or Heat Exchanger

Valve shown in "diverting" position to control outlet temperature. In dotted position, valve will "mix" to control inlet water to engine.

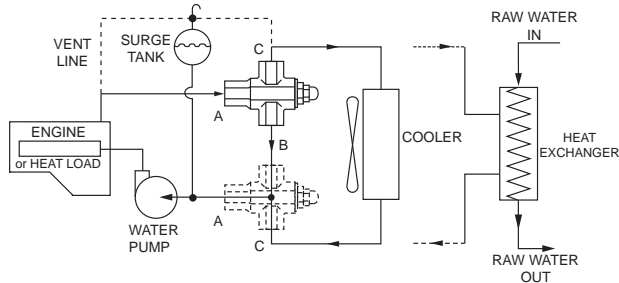

### Water Saving Application

Valve as shown maintains minimum flow through cooler to conserve water, requires internal leak port to permit small flow for sensing.

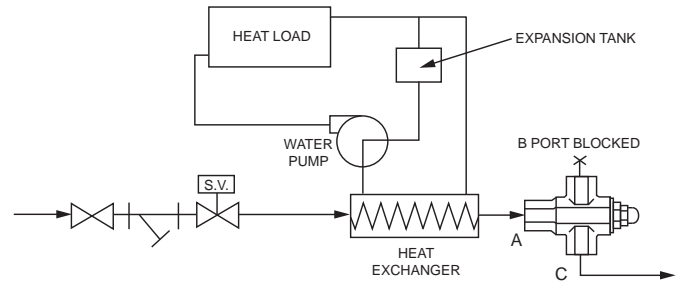

### Direct Cooling with Raw Water

Valve shown in "mixing" position to control temperature of inlet water to refrigeration system condenser. Valve in dotted position controls outlet temperature.

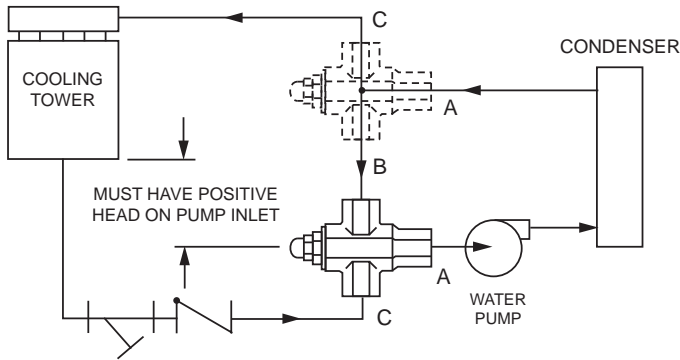

### Lube Oil Control

Valve shown in "diverting" position to control oil sump temperature. In dotted position, valve will "mix" to control oil temperature to bearings or manifold.

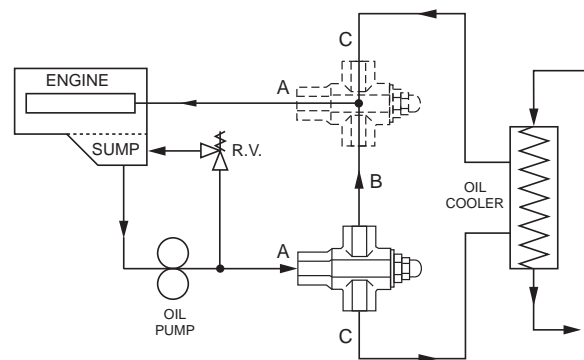

## Plumbing Diagrams

### For Mixing Applications

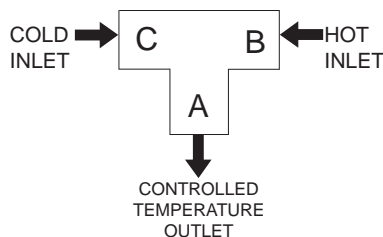

### For Diverting Applications

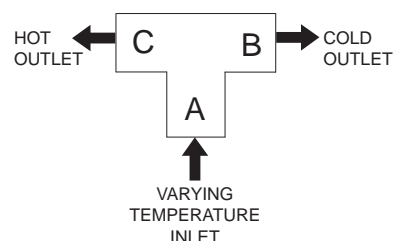

\*Customized temperature, material, and port positions available upon request



## Part Numbers & Ordering

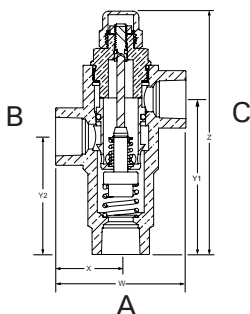

### 1/2" M/D

| Part Number <sup>1</sup> | Description   |
|--------------------------|---|
| 353-00X000-XXX           | 1/2" M/D Valve - 316 SS Body, 300 Series SS Internals |
| 353-02X000-XXX           | 1/2" M/D Valve - all 316 SS construction              |
| 353-01X000-XXX           | 1/2" M/D Valve - Bronze                               |

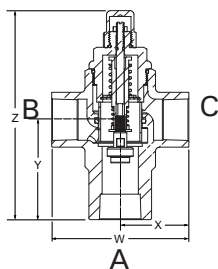

### 1" M/D

| Part Number <sup>1</sup> | Description                              |
|--------------------------|--|
| 356-00X000-XXX           | 1" M/D Valve - Bronze                    |
| 356-01X000-XXX           | 1" M/D Valve - 303 SS                    |
| 356-02X000-XXX           | 1" M/D Valve - 316 SS Special Order Only |

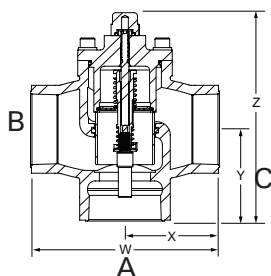

### 2" M/D

| Part Number <sup>1</sup> | Description       |
|--------------------------|-------------------|
| 359-0X4000-XXX           | 2" M/D Valve - SS |

## Dimensions & Capacities

| Size NPT | Body Material | W    |     | X    |    | Y         |    | Y1   |     | Y2   |     | Z    |     | Weight |      | C <sub>v</sub> | Maximum Operating Pressure | Maximum Operating Temperature | ANSI Body Compliance |
|----------|---------------|------|-----|------|----|-----------|----|------|-----|------|-----|------|-----|--------|------|----------------|----------------------------|-------------------------------|----------------------|
|          |               | IN   | MM  | IN   | MM | IN        | MM | IN   | MM  | IN   | MM  | IN   | MM  | Lb     | Kg   |                |                            |                               |                      |
| 1/2"     | SS            | 2.62 | 67  | 1.31 | 33 | N/A       |    | 3.12 | 79  | 2.38 | 60  | 4.90 | 124 | 1.5    | 0.6  | 2.7            | 350 PSIG (24 BAR)          | 250°F (121°C)                 | 300 Class            |
| 1/2"     | Bronze        |      |     |      |    | 250 Class |    |      |     |      |     |      |     |        |      |                |                            |                               |                      |
| 1"       | Bronze        | 4.37 | 111 | 2.20 | 56 | 3.19      | 81 | N/A  | N/A | N/A  | N/A | 6.70 | 170 | 5.0    | 2.27 | 10.0           | 250 PSIG (17.2 BAR)        |                               | 250 Class            |
| 1"       | SS            |      |     |      |    |           |    |      |     |      |     |      |     |        |      |                |                            | 150 Class                     |                      |
| 2"       | SS            | 6.00 | 152 | 3.00 | 76 | 3.00      | 76 |      |     |      |     | 6.80 | 173 | 11     | 5.0  | 18.0           |                            |                               |                      |

1. Seal material compatibility "X" available (replace singular X of part number with corresponding number below)

0. - Buna-N for air (to 250°F), water, fuel, oil, gas, and petroleum-based hydraulic oils.

1. - Viton for air (to 450°F), fuel, oil, gas, and petroleum-based hydraulic oils

2. - EPDM for air (to 300°F), water, steam, ketones, and synthetic hydraulic oils

3. - Fluorosilicone for air (to 400°F), aerospace industry petroleum oils/fuels, and diester-based lubricants

2. For most applications, pressure difference between the hot and cold ports should not exceed 10 PSI.

3. Set point temperatures "XXX" available: 035°F, 045°F, 050°F, 060°F, 070°F (+/- 8°F), 085°F, 090°F, 100°F, 105°F, 110°F, 125°F, 130°F (+/- 8°F), 135°F, 147°F (+/- 8°F), 152°F (+/- 8°F), 160°F, 170°F, 190°F, 200°F, 205°F, 210°F.

**Note:** Unless otherwise noted, during operation the valve will modulate the Cold side (C port) closed at 5°F below the set point, and the Hot side (B port) closed at 5°F above the set point.

4. Customized temperature, materials, and port positions available upon request.