



Instruction Sheet

Variable Speed - Analog Signal (00-VV) "00" and LoadMatch Cartridge Circulators

102-509

SUPERSEDES: May 11, 2018

Effective: March 4, 2020

Plant ID No. 001-4248

The Variable Speed - Analog Signal "00" Cartridge Circulator (00-VV) is a microprocessor-based pump designed to operate at different speeds based on an analog voltage signal input. Its ease of installation and operation allows for a wide variety of HVAC applications, such as maintaining a pressure differential or a setpoint temperature.

Sequence of Operation

Whenever the 00-VV is powered up, the green power LED turns on and the pump operates based on an analog input signal. The percent output (% OUT) LED flashes at different rates based on the speed of the pump. As the % OUT LED flashes faster it indicates a faster speed of the pump. A fully on LED indicates the pump is at 100% capacity.

Output Characteristic (DIP Switch 1)

The 00-VV accepts an analog signal in order to drive the pump at different speeds. The pump speed may be selected to change linearly or based on equal percentage characteristic. The output characteristic is selected via DIP switch 1.

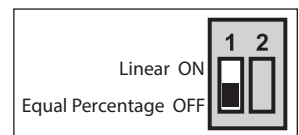

Linear Characteristic — DIP 1-ON

The linear output characteristic assumes there is a linear relationship between percent of flow of the pump and heat output of the terminal unit. Linear operation is typically used in applications in which the pump injects into a constant circulating loop, which includes the terminal unit.

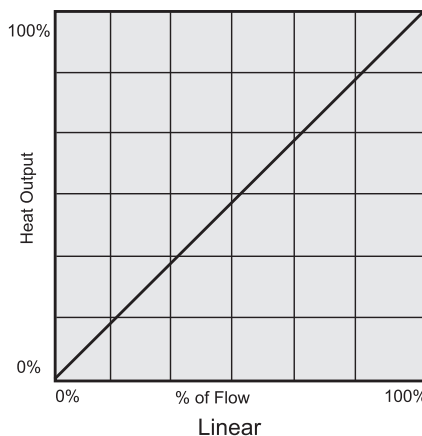

Equal Percentage Characteristic — DIP 1-OFF

The equal percentage output characteristic assumes there is a non-linear relationship between percent of flow of the pump and heat output of the terminal unit. In order to achieve the desired linear output, the 00-VV provides an equal percentage output. Equal percentage operation is typically used in applications in which the pump injects directly into the terminal unit.

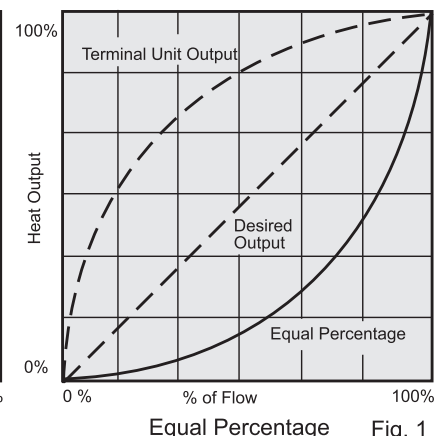
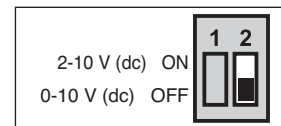

Fig. 1

Analog Signal (DIP Switch 2)

The control accepts either a 0-10 V (dc) or 2-10 V (dc) signal. The signal range is selectable via DIP switch 2. Once a signal is applied, the pump speed varies based on the selected output characteristic.



0-10 V (dc) / 0-20 mA — DIP 2-OFF

Whenever the signal is 0 V (dc), the percent speed output of the pump is 0%, and it increases to 100% when a 10 V (dc) signal is present.

If a 0-20 mA signal is used, install the 500 ohm 1/4 W resistor across the (COM) and (V+) terminals as shown in figure 2. Whenever the signal is 0 mA, the percent speed output of the pump is 0%, and it increases to 100% when a 20 mA signal is present.

2-10 V (dc) / 4-20 mA — DIP 2-ON

Whenever 2 V (dc) is present, the control operates the pump at 0% and it increases to 100% whenever 10 V (dc) signal is present.

If a 4-20 mA input signal is used, install the 500 ohm 1/4 W resistor across the (COM) and (V+) terminals as shown in figure 2. Whenever a 4 mA signal is present the pump operates at 0% output and it increases to 100% whenever 20 mA signal is present.

Automatic / Manual Operation Switch

The 00-VV allows the user to manually turn on the pump at full flow without an analog signal. This function is enabled by switching the Auto/ Man override switch in the upper-right corner of the board to MAN.

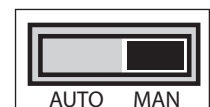

Exercising

During long periods of no operation, the 00-VV is designed to exercise for 10 seconds every 3 days of no operation in order to prevent precipitate build-up in the pump. The % OUT LED turns on during the exercising function.

Wiring and Troubleshooting

WARNING: Wiring connections must be made in accordance with all applicable electrical codes.

CAUTION: To prevent electrical shock, disconnect electric power to system at main fuse or circuit breaker box until installation is complete. When a service switch is installed, more than one disconnect switch may be required to deenergize this device for servicing.

Powering the Pump

Insert the line voltage wires through the knockout of the enclosure and connect the Live wire to the H terminal and the Neutral wire to the N terminal. Ensure that no power is present during this process. For your safety and protection of permanent damage to the micro-processor, this PC board includes a fuse wire. If the fuse wire blows, contact a Taco representative. Once power is applied, the power LED is turned on.

Analog Signal

0-10 V (dc) or 2-10 V (dc)

Connect the positive line of the analog signal into the (V+) terminal and the negative wire into the (COM) terminal.

To test the voltage input signal place a voltmeter between the (V+) and (COM) terminals.

0-20 mA or 4-20 mA

Connect the positive line of the analog signal into the (V+) terminal and the negative wire into the (COM) terminal. Connect the 500 ohm 1/4 W resistor across the (V+) and (COM) terminals.

To test the current input signal, place an ammeter in series between the (V+) terminal and the positive wire from the signal control.

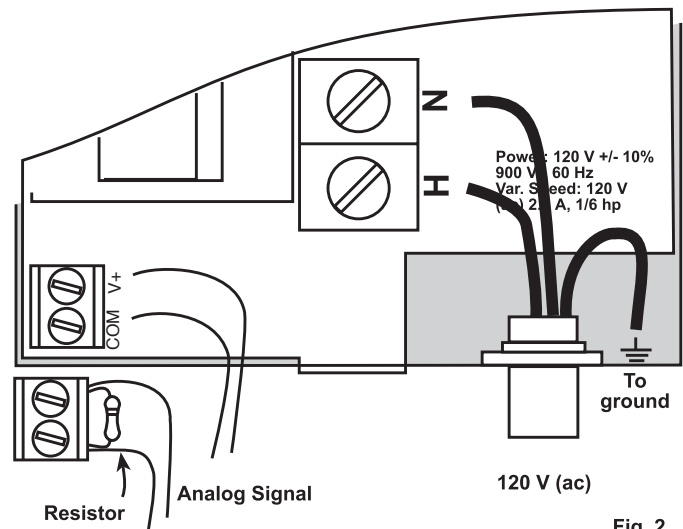
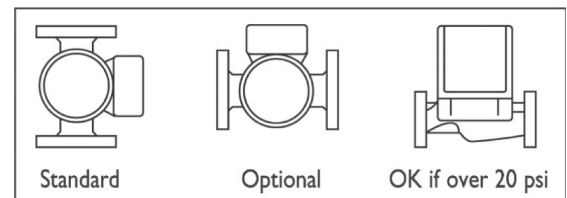

Fig. 2

Application

1. Maximum operating pressure: 125 psi (862 kPa) on all small "00" Series, 150 psi (1034 kPa) on all 009—0014 "00" series, 200 psi (1379 kPa) on all Load-Match Circulators.
2. Maximum water temperature not to exceed nameplate rating.
3. Cast iron circulators are to be used for closed loop systems. Bronze or stainless steel circulators are to be used for open loop, fresh water, or potable water systems.
4. Taco Cartridge circulator pumps are for indoor use only – employer uniquement a l'intérieur.



Installation

1. Mounting position – Circulator must be mounted with the motor in a horizontal position. It may be mounted vertically with the motor up, provided that the system pressure is at least 20 psi (138 kPa).
2. Rotating body – Body has an arrow on the front that indicates direction of flow. To rotate body, remove the four body bolts, rotate body and replace bolts. Make sure that the junction box is NOT located underneath the circulator. (The junction box must NOT be located in the 6 o'clock position, as viewed from the motor end.)
3. Electrical connections – Observe all applicable codes when connecting to power supply. The motor is impedance protected, and does not require overload protection. The pump cannot run backwards.

WARNING: Do not use in swimming pool or spa areas; pump has not been investigated for this application.

WARNING: In the event the retaining screws have been pulled out of the housing, DO NOT replace them. Use of any other screw may short out the stator windings, creating a risk of electrical shock.

CAUTION: When installing electrical connections, do not apply mechanical loads to the capacitor box; otherwise, retaining screws may be pulled out of the housing, making circulator unusable.

CAUTION: Installations at higher elevations over 5000 feet must have higher fill pressure of 20 psi to prevent pump cavitation and flashing. Premature failure may result. Adjust expansion tank pressure to equal fill pressure. A larger size expansion tank may be required.

CAUTION: Do not use flat rubber gaskets on pump flanges. Only use O-ring gaskets provided or leaking will result. Warranty will be void.

4. Fill system with tap water – The system must be filled before operating the circulator. The bearings are water lubricated and should not be allowed to operate dry. Filling the system will result in immediate lubrication of the bearings. It is always good practice to flush a new system of foreign matter before starting the circulator.
5. Circulator operation – Operate the circulator for 5 minutes at full speed (move AUTO / MAN switch to MAN position) immediately after filling system to purge remaining air from the bearing chamber. This is especially important when installing the circulator during the off-season. Be sure to change AUTO / MAN switch back to AUTO after system is purged.

CAUTION: 1. The addition of petroleum based fluids or certain chemical additives to systems utilizing TACO equipment voids the warranty.

2. Use supply wires suitable for 90°C – ATTENTION: Employer des fils d'alimentation adequats pour 90°C.

WARNING: To avoid electrical shock, disconnect the power supply to the circulator and the main electrical unit.

Replacing Cartridge Assembly

1. Disconnect the electrical supply.
2. Reduce system pressure to 0 psi and allow system to return to room temperature. Isolate the circulator by closing the service valves or draining the system.
3. Remove the body bolts and swing motor assembly away from the body.
4. Pull cartridge out of the motor housing.
5. Install replacement cartridge, making sure that the cover plate is between the cartridge flange and motor.
6. Make sure the replacement cartridge corresponds to the full circulator product number. A complete parts list is available from your local plumbing supply wholesaler.
7. Reassemble the circulator using the new gasket and bolts supplied.
8. Follow the “Installation” procedure to start up the circulator.

Replacing the Integral Flow Check (IFC)

1. Use needle nose pliers to remove IFC, position pliers around hub of valve body, spin IFC to free the body and carefully remove valve to avoid breakage.
2. Make sure the IFC pocket is clean and free of any debris or particulates.
3. Position IFC into the machined pocket inside the casing as shown in the diagrams below. Firmly press the IFC into the pocket until it snaps into place.
4. Replace O-ring and reattach motor housing if required; or reinstall entire circulator with new flange gasket.
5. Open water supply and refill system. Check for any leaks.
6. Reconnect power to circulator and check for proper operation of system.

Replacing Circuit Board

1. Disconnect the electrical supply and all field wiring to the circuit board.
2. Unplug the 3-pin plastic connector that connects the motor to the circuit board.
3. Bend the lip of the capacitor base to ease the removal of the circuit board. Pull the circuit board up and out.
4. Reverse directions to install the new circuit board.

Notes

Figure 3: View of IFC on suction side of "00" sweat connection pump casing, with motor housing removed.

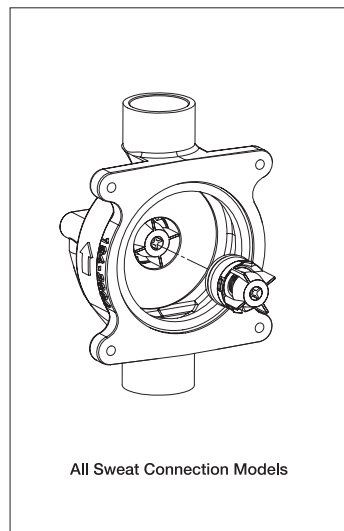
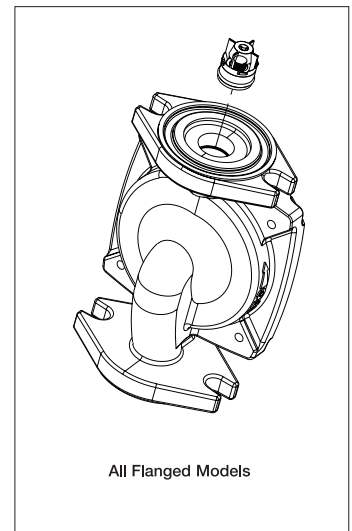

Figure 4: View of IFC in discharge flange of "00" pump casing.



Taco Comfort Solutions® A Taco Family Company

Taco, Inc., 1160 Cranston Street, Cranston, RI 02920 | Tel: (401) 942-8000 | FAX: (401) 942-2360

Taco (Canada), Ltd., 8450 Lawson Road, Suite #3, Milton, Ontario L9T 0J8 | Tel: (905) 564-9422 | FAX: (905) 564-9436

Visit our web site: www.TacoComfort.com | Printed in USA | ©2020 Taco, Inc.

