

spirax sarco®

DCV 4 Wafer Check Valve

The DCV 4 Wafer Check Valve is designed to be fitted between ANSI flanges. It is suitable for use on a wide range of fluids for applications in process lines, hot water systems, steam and condensate systems.

Model ⇄	DCV 4
Sizes	1/2", 3/4", 1", 1-1/2", 2", 3", 4"
Connections	ANSI 150 or 300
Construction	Austenitic Stainless Steel
Standard Internals	Standard Disk: Metal - Metal Seat Standard Spring: Stainless Steel
Soft Seat Options	Viton (for oils & gases): temp. limits: -5°F to +482°F (-15°C to +250°C) EPDM (for water): temp. limits: -58°F to +302°F (-50°C to +150°C)
Spring Options	high temperature nimonic or supplied without spring

LIMITING OPERATING CONDITIONS

Maximum design conditions ANSI 300

Max. Operating Pressure (PMO)	725 psig (50 barg)
Max. Operating Temperature (TMO)	572°F (300°C) with standard spring 752°F (400°C) nimonic high temperature spring 752°F (400°C) without spring

Minimum temperature (Standard Disc) -58°F (-50°C)

Maximum cold hydraulic test 1102 psig (76 barg)

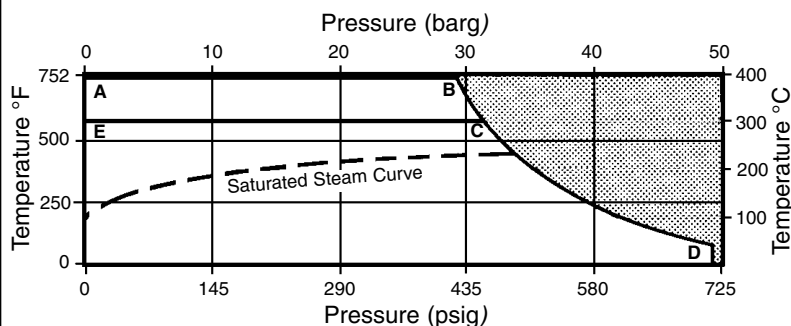

E, C, D — Standard spring
A, B, D — Nimonic spring & without spring
■ The product must not be used in this region.

CONSTRUCTION MATERIALS

No.	Part	Material	
1	Body	Austenitic Stainless Steel	ASTM A351 CF3M
2	Disc	Austenitic Stainless Steel	BS 1449 316 S 11
3	Spring Retainer	Austenitic Stainless Steel	BS 1449 316 S 11
4	Standard Spring	Austenitic Stainless Steel	BS2056 316 S 42
	High Temperature Spring	Nickel alloy	Nimonic 90

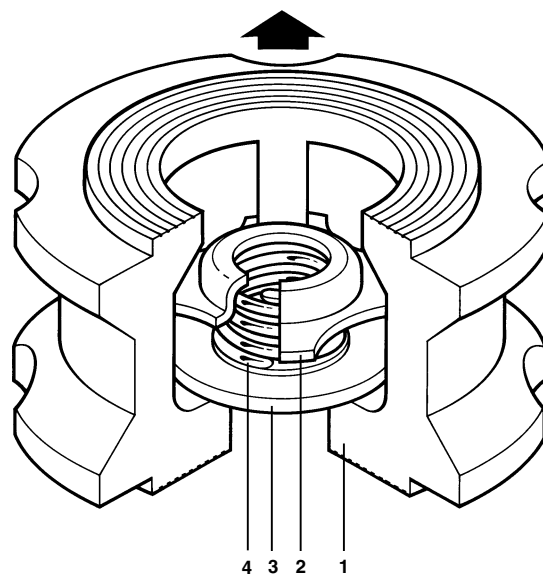

OPENING PRESSURES

Differential pressures with Zero Flow (in **psi** and **mbar**)

Flow	Size						
	1/2"	3/4"	1"	1-1/2"	2"	3"	4"
↑	0.36 25	0.36 25	0.36 25	0.41 28	0.42 29	0.45 31	0.48 33
→	0.33 22.5	0.33 22.5	0.33 22.5	0.35 24	0.36 24.5	0.37 25.5	0.38 26.5
↓	0.29 20	0.29 20	0.29 20	0.29 20	0.29 20	0.29 20	0.29 20

Where lowest opening pressures are required, valves without springs can be installed in vertical pipes with bottom-to-top flow.

Without spring

↑	0.04 2.5	0.04 2.5	0.04 2.5	0.06 4	0.07 4.5	0.08 5.5	0.09 6.5
---	--------------------	--------------------	--------------------	------------------	--------------------	--------------------	--------------------

STANDARDS

Designed and manufactured in accordance with BS 7438.

Standard of shut off

Standard valves conform to DIN 3230 Part 3, BN 2. Valves conforming to DIN 3230 Part 3, BO3 available on request. Soft seated versions meet DIN 3230 Part 3 BN1 and BO1 provided a differential pressure exists.

DCV 4 Wafer Check Valve

PRESSURE LOSS DIAGRAM

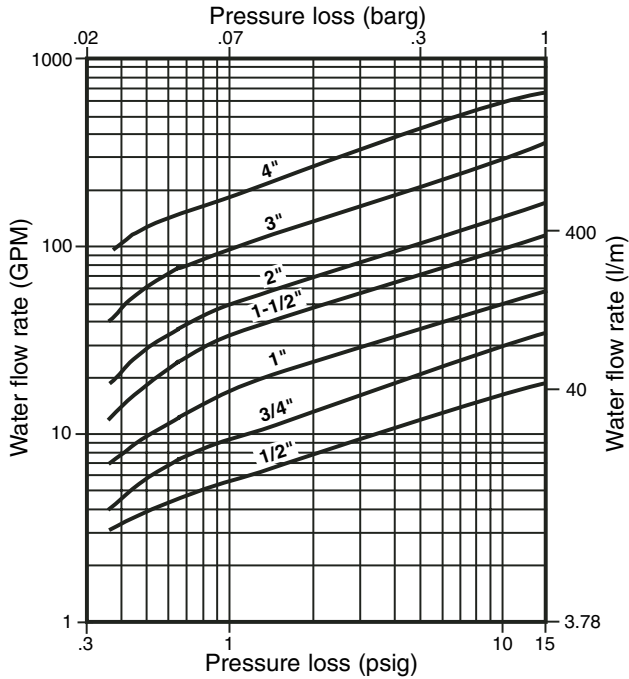

Pressure loss diagram with open valve at 68°F (20°C). The values indicated are applicable to spring loaded valves with horizontal flow. With vertical flow, insignificant deviations occur only within the range of partial opening. The curves given in the chart are valid for water at 68°F (20°C). To determine the pressure drop for other fluids, the equivalent water volume flowrate must be calculated and used in the graph.

$$V_w = \sqrt{S.G.} \times V$$

V_w = Equivalent water volume flow in GPM

S.G. = Specific Gravity

V = Volume of fluid GPM

Pressure loss information for steam, compressed air, and gases is available from Spirax Sarco.

INSTALLATION

DCV 4 Wafer Check Valves must be fitted in accordance with the direction of flow arrow indicating correct fluid flow direction. When fitted with a spring they can be installed in any plane. When supplied without a spring these must be fitted in a vertical flow line with the flow from bottom to top.

Note: Disc Check valves are not suitable for use where heavily pulsating flow exists, such as close to a compressor.

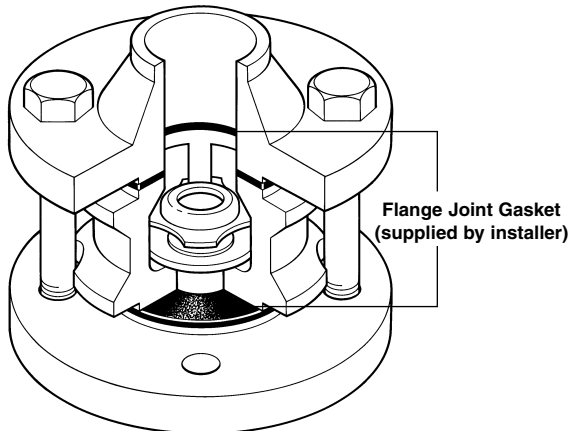

DIMENSIONS (NOMINAL) IN INCHES AND MILLIMETERS

Size	A	B	C	D	E	F	Weight
1/2"	2.1 54	1.9 47	1.5 38	1 25	.9 22.4	.5 15	0.53 lb 0.24 kg
3/4"	2.7 67	2.3 57	1.8 46	1.3 31	1.5 27.4	.75 20	0.90 lb 0.41 kg
1"	2.9 73	2.7 67	2.1 54	1.4 35	1.3 33.2	1 25	1.19 lb 0.54 kg
1-1/2"	3.8 95	3.4 86	3 76	1.8 45	2 49.2	1.5 40	2.54 lb 1.15 kg
2"	4.4 111	4.1 105	3.8 95	2.3 56	2.3 59.2	2 50	4.06 lb 1.84 kg
3"	5.9 149	5.3 136	5.1 130	2.8 71	3.5 90.2	3 80	8.14 lb 3.69 kg
4"	7.1 181	6.9 174	6.3 160	3.1 80	4.4 111.2	4 100	12.57 lb 5.70 kg

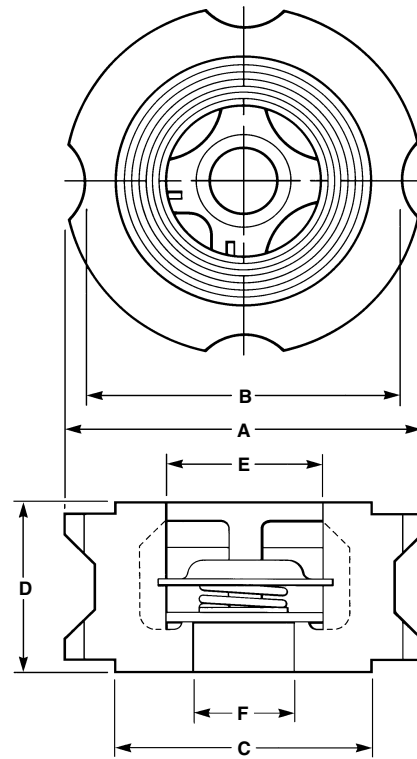

HOW TO SPECIFY

Spirax Sarco DCV 4 Wafer Check Valve for fitting between ANSI 300 flanges.

Valve bodies that are marked with:

- "N" — Have a nimonic spring fitted for operating temperatures up to 752°F
- "W" — Have no return spring fitted. These must be fitted with flow from bottom to top in a vertical line.
- "T" — Valves tested to DIN 3230 Part 3, BO3.

Discs that are marked with a:

- "V" — Have a Viton soft seating face—temperature limit 482°F
- "E" — Have an EPDM soft seating face—temperature limit 302°F.

HOW TO ORDER

1-1/2" Spirax Sarco DCV 4 Wafer Check Valve, steam at 400 psi, Austenitic stainless steel body to fit between ANSI 300 flanges.

TI-7-222-US 09.97