

spirax sarco

Steel Liquid Drain Trap F-150V, F-300V

The float-operated liquid drain trap discharges continuously in direct response to variations in liquid flow rate, assuring thorough drainage of the system.

Model	F-150V	F-300V
PMO	150 psig	300 psig
Sizes	1/2"	
Connections	NPT	
Construction	Stainless Steel Body Carbon Steel Cover	
Options	SW to ANSI B16.11	

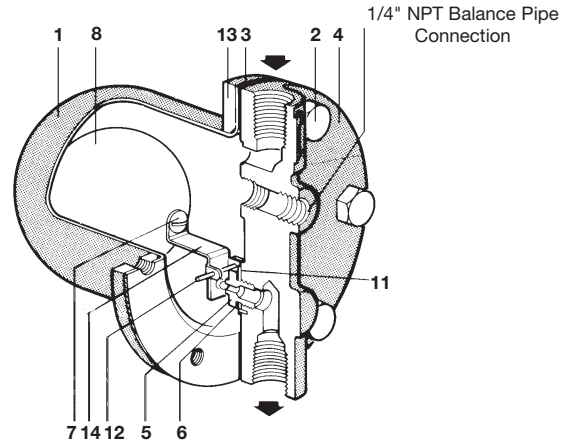

Typical Applications

Receiver and air line drainage, draining a liquid from its vapor phase.

Limiting Operating Conditions

Max. Operating Pressure (PMO)

Specific Gravity	F-150V		F-300V	
	psig	barg	psig	barg
1.0	150	10.3	300	20.7
.95	150	10.3	300	20.7
.90	150	10.3	300	20.7
.85	150	10.3	300	20.7
.80	138	9.5	282	19.4
.75	119	8.1	243	16.7
.70	100	6.8	203	13.9
.65	80	5.5	164	11.2
.60	61	4.2	125	8.6
.55	42	2.8	86	5.9
.50	23	1.5	46	3.1

Max. Operating Temperature 750°F (399°C)

Pressure Shell Design Conditions

PMA 450 psig/0-750°F 31 barg/0-399°C
Max. allowable pressure

TMA 750°F/0-450 psig 399°C/0-31 barg
Max. allowable temperature

Construction Materials

No.	Part	Material
1	Body	Stainless Steel AISI 304
2	Cover Screws	Steel ASTM A449 Type 1
3	Cover Gasket	Graphite
4	Cover	Forged Steel ASTM A105
5	Valve Seat	Stainless Steel AISI 420F
6	Valve Seat Gasket	Stainless Steel AISI 303
7	Float Screw & washer	Stainless Steel AISI 304
8	Ball Float	Stainless Steel AISI 304
11	Valve Seat Bracket	Stainless Steel AISI 301
12	Pivot Pin	Stainless Steel AISI 303
13	Body Retaining Ring	Forged Steel ASTM A105
14	Lever & Ball Head	Stainless Steel AISI 301/304 Lever AISI 440 Ball Head

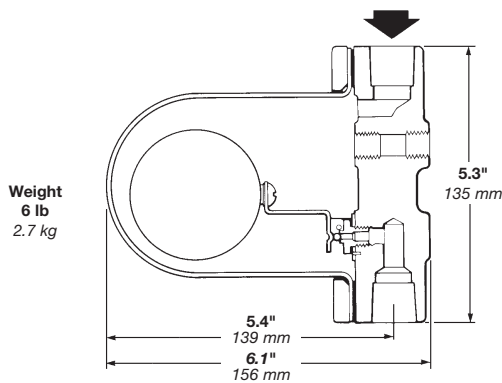

Cold Water Capacity lb/h

psi bar	Differential pressure													
	1	2	5	10	20	30	50	65	75	100	125	150	250	300
F-150V	150	200	295	395	530	625	785	880	940	1060	1160	1250	-	-
F-300V	80	105	145	210	280	335	420	470	500	570	620	680	850	920

For kg/h, multiply lb/hr by .454

Local regulation may restrict the use of this product below the conditions quoted. Limiting conditions refer to standard connections only.
In the interests of development and improvement of the product, we reserve the right to change the specification.

TI-7-310-US 2.14

Steel Liquid Drain Trap

F-150V, F-300V

Conversion Factors

for equivalent cold water capacity of light liquids

Specific gravity	.95-.99	.90-.94	.85-.89	.80-.84	.75-.79	.70-.74	.65-.69	.60-.64	.55-.59	.50-.54
Conversion Factor	1.03	1.06	1.09	1.12	1.16	1.20	1.24	1.29	1.35	1.42

Draining Cold Water & Liquids of specific gravity 1.0

Obtain the required cold water capacity by multiplying the peak load by a safety factor of 1.5. Select the drain trap from the capacity table which satisfies the required cold water capacity and operates at the minimum pressure differential of the application.

Sample Specification

The liquid drain trap shall be of the float type with screwed NPT connections. Valve mechanism shall be stainless steel with hardened working surfaces designed to retain a water seal at all times. A 1/4" NPT tapping shall be provided for a balance pipe. All internals are to be renewable and field serviceable.

Draining Liquids of specific gravity 0.5 to 0.95

Determine the "Equivalent Cold Water Capacity" of the light liquid by multiplying its peak load (include a safety factor of 1.5) by the conversion factor given in the table above. If the maximum load is accurately known, the safety factor can be reduced or eliminated.

Refer next to Limiting Conditions table which gives the maximum operating pressure with various gravity liquids. For liquids between those listed, use the next lower specific gravity. Determine the maximum operating pressure equal to, or greater than, the inlet pressure of the application.

Installation

The trap must be fitted in a vertical pipe line with direction of flow as indicated and so that the float mechanism is free to rise and fall in a vertical plane.

The cover is provided with a 1/4" tapping for a balance pipe, which is essential for satisfactory operation of this unit. The balance pipe must be connected with a continuous rise between the tapping provided on the trap and the vessel being drained. The trap discharge should be piped to a safe place.

Maintenance

This product can be maintained without disturbing the piping connections. Complete isolation of the trap from both supply and return line is required before any servicing is performed. The trap should be disassembled periodically for inspection and cleaning of the valve head and seat. Worn or damaged parts should be replaced using a complete repair kit.

Complete installation and maintenance instructions are given in the IMI 7.306 which accompanies the product.

Liquid drain traps can be used to drain most gases.

However, some applications, particularly those involving hazardous or unusual fluids, may be subject to regulation or may otherwise require special consideration.

Spirax Sarco will endeavor to provide whatever data is necessary to assist in product selection.

Spare Parts

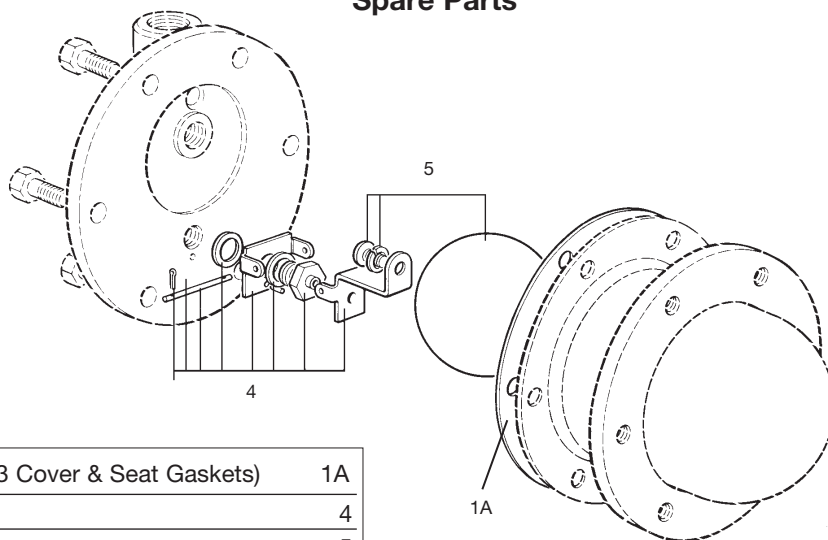

Cover Gasket (Set of 3 Cover & Seat Gaskets)	1A
Valve Mechanism Kit	4
Float Kit	5

TI-7-310-US 2.14

Spirax Sarco, Inc., 1150 Northpoint Blvd, Blythewood, SC 29016

Telephone: (803) 714-2000 FAX (803) 714-2222

© Spirax Sarco, Inc. 2014

Liquid Drain Traps