



Threaded Outlet

Specification: ASME B31.1 & MSS-SP97
Also in ASME B31.3 and ASME BPVC Sec I & Sec VIII Div 2

Material: Available in a complete range of Carbon Steels, Stainless Steels, Alloy Steels and Non-ferrous metals certified to ASTM, ASME, and Military standards.

Sizes: 1/8" - 6" in Class 3000 and 6000
Also available in class 9000

Threads: American National Standard Taper Pipe Threads
NPT (ANSI/ASME B1.20.1-1983)
Also available in other thread forms: NPTF, NPSC, NPSM, NGT, SAE, BSPT, BSPP and in any combination.
Left hand threads available upon request.

Welding onto Header Pipe

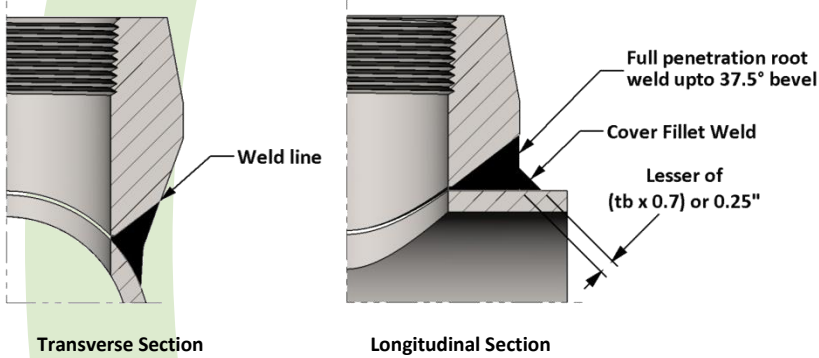

Threaded Pressure Class	Pipe Schedule
Class 3000	S160
Class 6000	XXH

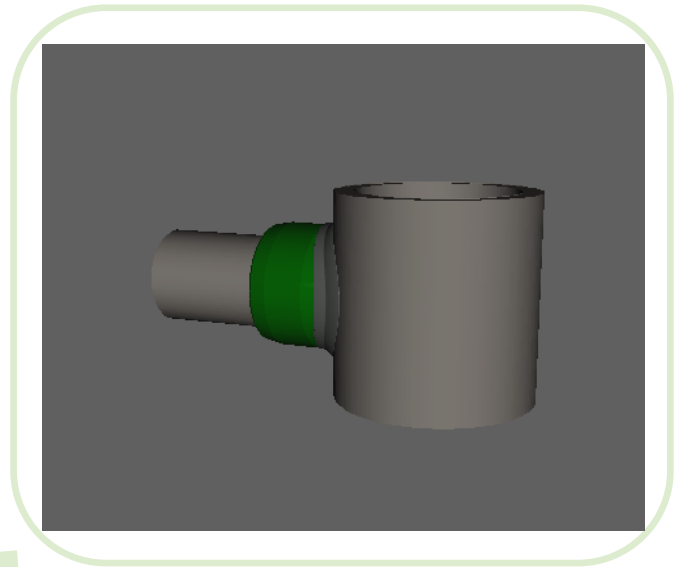

Active
3D
Model

All dimensions are in inches • Weights are based on Carbon Steel

PIPE SIZE	CLASS 3000 – Figure No. 03502												
	1/8	1/4	3/8	1/2	3/4	1	1-1/4	1-1/2	2	2-1/2	3	3-1/2	4
A	0.750	0.750	0.813	1.000	1.063	1.313	1.313	1.375	1.500	1.813	2.000	2.125	2.250
C	0.328	0.438	0.563	0.703	0.906	1.141	1.468	1.688	2.188	2.563	3.188	3.688	4.188
LBS	0.07	0.12	0.16	0.21	0.36	0.59	0.84	1.00	1.72	2.90	4.24	4.40	6.91

PIPE SIZE	CLASS 6000 – Figure No. 06502												
	1/8	1/4	3/8	1/2	3/4	1	1-1/4	1-1/2	2	2-1/2	3	3-1/2	4
A	1.125	1.125	1.125	1.250	1.438	1.563	1.625	1.688	2.063	2.688	2.688	---	3.313
C	0.328	0.438	0.563	0.703	0.906	1.141	1.468	1.688	2.188	2.563	3.188	---	4.188
LBS	0.15	0.21	0.28	0.42	0.59	1.02	1.60	1.98	3.06	6.35	10.12	---	19.72