



- G1724** WideArea™ Eye/Face Wash, Wall Mounted, Stainless Steel Bowl
- G1724P** WideArea™ Eye/Face Wash, Wall Mounted, Plastic Bowl



Application: WideArea™ eye/face wash for wall mounting. Four GS-Plus™ spray-type outlet heads deliver a flood of water over a wide area of coverage for complete rinsing of eyes and face.

Spray Head Assembly: Four GS-Plus™ spray heads. Each head has a “flip top” dust cover, internal flow control and filter to remove impurities from the water flow.

Valve: 1/2" IPS chrome plated brass stay-open ball valve. Valve is US-made with chrome plated brass ball and Teflon® seals.

Bowl: 11-1/2" diameter. Bowl is stainless steel (G1724) or orange ABS plastic (G1724P).

Mounting: Heavy duty cast aluminum wall bracket with corrosion resistant powder coated finish.

Supply: 1/2" NPT female inlet.

Waste: 1-1/4" NPT female outlet.

Sign: ANSI-compliant identification sign.

Quality Assurance: Unit is completely assembled and water tested prior to shipment.

Available Options

- DC** Stainless steel dust cover for each spray head.
- HS** Auxiliary hand-held drench hose for rinsing eyes, face or body.
- SC** Self-closing ball valve. *Note: Eye/face washes with self-closing valves do not comply with ANSI Z358.1-2014.*
- GRN** Green ABS plastic bowl.
- YEL** Yellow ABS plastic bowl.
- T** Chrome plated brass tailpiece and trap with 1-1/2" IPS waste connection.
- TP** 1-1/2" OD Chrome plated brass tailpiece.
- TMV** G3600LF thermostatic mixing valve precisely blends hot and cold water to deliver warm (tepid) water as required by ANSI Z358.1-2014. Refer to “Tempering Units” section for complete technical and product selection information.



□ **G1724** WideArea™ Eye/Face Wash, Wall Mounted, Stainless Steel Bowl

□ **G1724P** WideArea™ Eye/Face Wash, Wall Mounted, Plastic Bowl

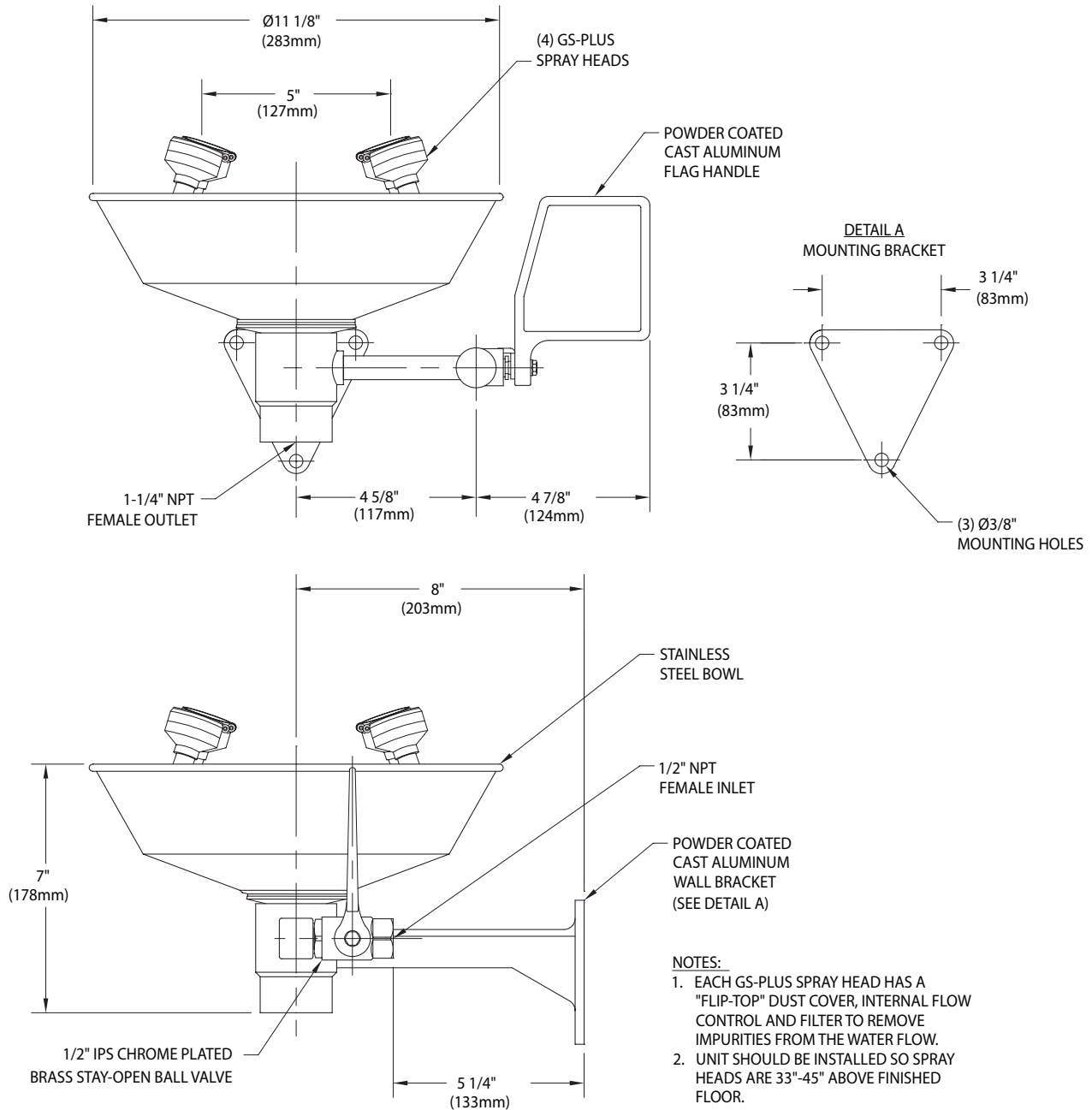

THIS SPACE FOR ARCHITECT/ENGINEER APPROVAL

Due to continuing product improvement, the information contained in this document is subject to change without notice. All dimensions are $\pm 1/4"$ (6mm). rev. 0115

Sign Included

