

FIG. 7001SS

Stainless Steel Flexible Coupling



The Figure 7001SS Flexible Coupling is a Stainless Steel coupling made of ASTM A-743/A743M cast stainless steel which is the cast equivalent to 316 Stainless Steel. It is designed for installation on Stainless Steel schedule 10 and 40 pipe and fittings. The stainless steel material is suitable for a variety of aggressive corrosive environments. The Figure 7001SS flexible coupling can accommodate some angular, rotational and axial pipe movement. It is capable of pressures up to 750 psi (41.4 bar) depending on pipe size and wall thickness.

MATERIAL SPECIFICATIONS

STAINLESS STEEL BOLTS:

Stainless steel bolts are metric track head bolts conforming to ASTM A 193M Class 2, Type 316 Grade B8M. Bolts are coated with an anti-galling agent.

STAINLESS STEEL NUTS:

Class 2 stainless steel nuts are heavy hex nuts conforming to ASTM A 194M, Type 316, Grade 8M.

STAINLESS STEEL HOUSING:

Type 316L, ASTM A 743/A 743M – Standard specification for castings, iron-chromium, iron-chromium-nickel, corrosion resistant; for general application Grade CR-8M. Tensile strength, minimum 70,000 psi (4826.3 bar). Yield strength, minimum 30,000 psi (2068.4 bar). Elongation in 2" (50mm) minimum 30%.

GASKETS: Materials

Properties as designated in accordance with ASTM D 2000

- Grade "EP" EPDM (Green and Red color code)
-40°F to 250°F (Service Temperature Range) (-40°C to 121°C)
Recommended for water service, diluted acids, alkaline solutions, oil-free air and many other chemical services.
NOT FOR USE IN PETROLEUM APPLICATIONS.

For hot water applications the use of Gruvlok Extreme Temperature lubricant is recommended.

- Grade "T" Nitrile (Orange color code)
-20°F to 180°F (Service Temperature Range)(-29°C to 82°C)
Recommended for petroleum applications, air with oil vapors and vegetable and mineral oils.
NOT FOR USE IN HOT WATER OR HOT AIR
- Grade "O" Fluoro-Elastomer (Blue color code)
20°F to 300°F (Service Temperature Range)(-7°C to 149°C)
Recommended for high temperature resistance to oxidizing acids, petroleum oils, hydraulic fluids, halogenated hydrocarbons and lubricants.

GASKET TYPE:

- Standard C Style (1" - 8")
- Flush Gap (1" - 8")

LUBRICATION:

- Standard Gruvlok
- Gruvlok Xtreme™ (Do Not use with Grade "L")

PROJECT INFORMATION		APPROVAL STAMP	
Project:		<input type="checkbox"/> Approved	
Address:		<input type="checkbox"/> Approved as noted	
Contractor:		<input type="checkbox"/> Not approved	
Engineer:		Remarks:	
Submittal Date:			
Notes 1:			
Notes 2:			

FIG. 7001SS

Stainless Steel Flexible Coupling

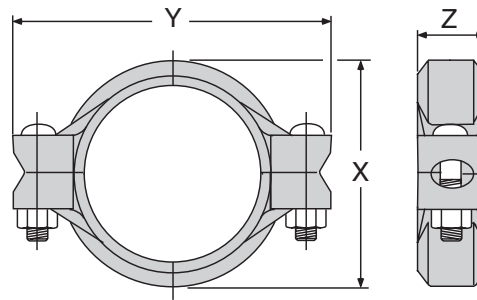

FIGURE 7001SS STAINLESS STEEL FLEXIBLE COUPLING

Nominal Size	O.D.	Max. Working Pressure [†]	Max. End Load [†]	Max. End Gap* [‡]	Deflection from \bar{C}		Coupling Dimensions			Coupling Bolts		Approx. Wt. Ea.
					Per Coupling	of Pipe	X	Y	Z	Qty.	Size	
<i>In./DN(mm)</i>	<i>In./mm</i>	<i>PSI/bar</i>	<i>Lbs./kN</i>	<i>In./mm</i>	<i>Degrees(-Minutes)'</i>	<i>In./ft-mm/m</i>	<i>In./mm</i>	<i>In./mm</i>	<i>In./mm</i>		<i>In./mm</i>	<i>Lbs./kg</i>
1 25	1.315 33.4	750 51.7	1.019 4.5	0.13 3.3	5° 26'	0.90 95.1	2.70 68.6	3.72 94.5	1.75 44.4	2	³ / ₈ x 2 ¹ / ₄ M10 x 57	1.3 0.6
1 ¹ / ₄ 32	1.660 42.4	750 51.7	1.623 7.2	0.13 3.3	4° 19'	0.90 75.0	2.92 74.1	4.19 106.4	1.80 45.7	2	³ / ₈ x 2 ¹ / ₄ M10 x 57	1.7 0.7
1 ¹ / ₂ 40	1.900 48.3	750 51.7	2.127 9.5	0.13 3.3	3° 46'	0.79 65.8	3.04 77.2	4.42 112.8	1.80 45.7	2	³ / ₈ x 2 ¹ / ₄ M10 x 57	1.8 0.8
2 50	2.375 60.3	500 34.5	2.215 9.9	0.13 3.3	3° 1'	0.63 52.5	3.38 85.8	4.97 126.2	1.76 44.7	2	³ / ₈ x 2 ¹ / ₄ M10 x 57	2.1 0.8
2 ¹ / ₂ 65	2.875 73.0	500 34.5	3.246 14.4	0.13 3.3	2° 29'	0.52 43.3	4.00 101	5.68 144.2	1.76 44.7	2	³ / ₈ x 2 ¹ / ₄ M10 x 57	2.7 1.2
3 80	3.500 88.9	500 34.5	4.810 21.4	0.13 3.3	2° 3'	0.43 35.8	4.63 117.6	6.50 165.1	1.85 46.998	2	¹ / ₂ x 3 M12 x 76	3.8 1.7
4 100	4.500 114.3	500 34.5	7.952 35.3	0.25 6.4	3° 11'	0.67 55.8	5.69 148.1	7.90 200.6	2.00 50.8	2	¹ / ₂ x 3 M12 x 76	5.2 1.8
5 125	5.563 141.3	450 31.0	10.933 48.7	0.25 6.4	2° 35'	0.54 45.0	6.96 176.8	9.71 246.6	2.04 51.8	2	⁵ / ₈ x 3 ¹ / ₄ M16 x 83	7.4 3.3
139.7mm 125	5.500 139.7	450 31.0	10.691 47.6	0.25 6.4	2° 36'	0.55 45.5	6.81 173.0	9.75 247.7	2.06 52.3	2	— M16 x 83	7.2 3.3
6 150	6.625 168.3	450 31.0	15.512 69.0	0.25 6.4	2° 10'	0.45 37.5	8.02 203.7	10.75 273.0	2.04 51.8	2	⁵ / ₈ x 3 ¹ / ₄ M16 x 83	8.4 3.8
8 200	8.625 219.1	450 31.0	29.261 117	0.25 6.4	1° 40'	0.35 29.2	10.25 260.3	13.56 344.4	2.31 58.6	2	³ / ₄ x 4 ³ / ₄ M20 x 121	15.2 6.69

NOTE:

* Maximum available gap between pipe ends. Minimum gap = 0.

† Maximum Pressure and End Load are total from all loads based on schedule 40 stainless steel pipe. Pressure ratings and end loads may differ for other pipe materials and/or wall thicknesses. Contact an Anvil Sales Representative for details.

‡ Max End Gap and Deflection is for cut grooved standard weight stainless steel pipe. Values for roll grooved pipe will be half that of cut grooved.