

30E Angle Stop Check Valve

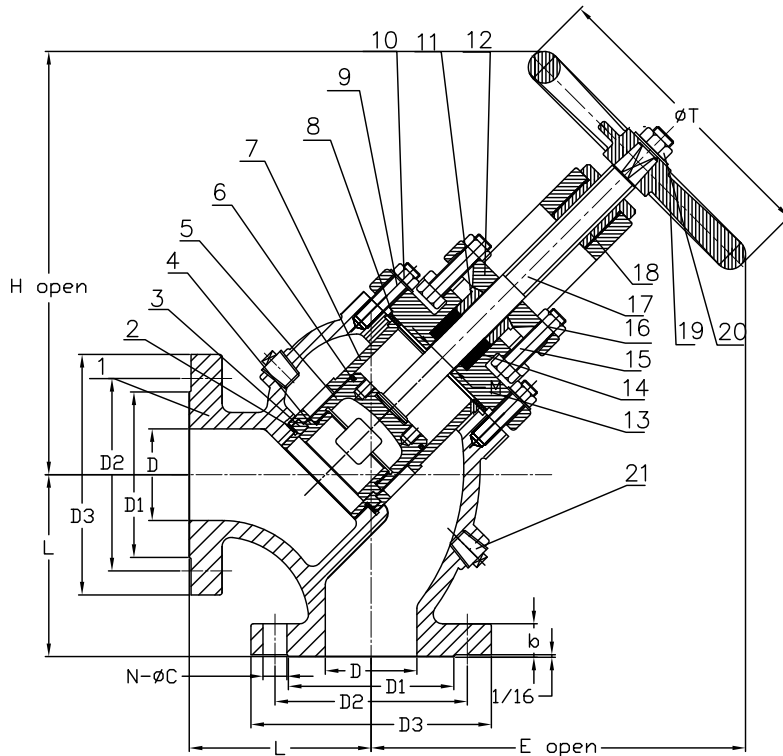

Materials of Construction

No.	Description	Material	ASTM
1	Body	Ductile Iron	A536
2	Body Seat Gasket	Graphite	
3	Body Seat Ring	Cast Bronze	B62
4	Disc Seal	Cast Bronze	B62
5	Disc	Ductile Iron	A536
6	Piston Ring	Alloy Cast Iron	
7	Disc Guide	Ductile Iron	A536
8	Body Gasket	Graphite	
9	Bolts	Steel	A193 B7
10	Nuts	Steel	A194 2H
11	Packing Gland	Cast Brass	B62
12	Gland Follower	Ductile Iron	A536
13	Bonnet	Ductile Iron	A536
14	Packing	Die-formed Compressed Graphite	
15	Bolts	Steel	A193 B7
16	Nuts	Steel	A194 2H
17	Stem	Stainless Steel	410
18	Stem Nut	Cast Brass	B62
19	Handwheel	Cast Iron	A126 B
20	Nut	Steel	A194 2H
21	Drain Plug	Stainless Steel	304

See pages 23 - 26 for sizing and other Technical Data

NOTE: Contact your CRANE® representative if you wish to have basic flow calculations performed by CRANE® to advise the possible sizes appropriate for your application.

Features:

- Valve designed for steam applications that operate between 100 and 250 psig.
- The Stop-Check feature of this valve requires a minimum of 50 psi pressure differential between piping system and boiler to operate properly.

2 1/2" - 6" Valves	1/2" NPT Plug
6" - 10" Valves	3/4" NPT Plug

Dimensions and Weights

Inches (millimeters) - Pounds (kilograms)

Valve Size	Dimensions										WT	
	D	D1	D2	D3	L	b	N - øC	M	H (Open)	E (Open)		T
2 1/2	2.50	4.94	5.86	7.50	5.75	1.00	8 - ø7/8	1.13	13.87	12.85	10.00	86
	(64)	(125)	(149)	(191)	(146)	(25)		(29)	(352)	(326)	(254)	(39)
3	3.00	5.69	6.63	8.25	6.25	1.13	8 - ø7/8	1.13	16.00	14.37	10.00	123
	(76)	(145)	(168)	(210)	(159)	(29)		(29)	(406)	(364)	(254)	(55)
4	4.00	6.31	7.86	10.00	7.00	1.25	8 - ø7/8	1.25	18.00	15.71	10.13	186
	(102)	(160)	(200)	(254)	(178)	(32)		(32)	(457)	(399)	(257)	(84)
5	5.00	8.31	9.25	11.00	7.88	1.38	8 - ø7/8	1.50	21.35	18.67	14.00	250
	(127)	(211)	(235)	(279)	(200)	(35)		(38)	(542)	(474)	(355)	(113)
6	6.00	9.69	10.63	12.50	8.75	1.44	12 - ø7/8	1.50	24.76	21.93	17.75	340
	(152)	(246)	(270)	(318)	(222)	(37)		(38)	(628)	(557)	(450)	(154)
8	8.00	11.94	13.00	15.00	10.50	1.63	12 - ø1	1.63	32.79	28.26	20.00	640
	(203)	(303)	(330)	(381)	(267)	(41)		(41)	(832)	(717)	(508)	(291)
10	10.00	14.06	15.25	17.50	12.25	1.88	16 - ø1 1/8	1.75	33.98	29.25	20.00	1025
	(254)	(357)	(387)	(445)	(311)	(48)		(44)	(863)	(742)	(508)	(465)