



JOB NAME:	CONTRACTOR:
JOB LOCATION:	APPROVAL:
ENGINEER:	CONTRACTOR P.O.:
APPROVAL:	REPRESENTATIVE:

8P766000

766000 2-WAY STAINLESS STEEL, ANSI 150 FLANGED, SPLIT BODY STYLE, DIRECT MOUNT, FULL PORT BALL VALVE WITH DOUBLE ACTING ACTUATOR

SIZES 1" TO 4"

8P766002

766000 2-WAY STAINLESS STEEL, ANSI 150 FLANGED, SPLIT BODY STYLE, DIRECT MOUNT, FULL PORT BALL VALVE WITH SPRING RETURN ACTUATOR

SIZES 1" TO 4"

SPECIFICATIONS

The 8E766001 series pneumatic actuator assembled package features the 766000 series ANSI Class 150, full port, stainless steel split body, ISO 5211 direct mount flanged ball valve. This valve is designed to ANSI 16.5, ANSI 16.10, and ANSI 16.34. It is also certified to API 607, 6th edition, and meets NACE MR 0175 and NACE MR 0103. A grounded ball & stem is standard.

The Valbia pneumatic actuator comes with a hard-anodized aluminum body, and powder coated end caps. In addition, all Valbia pneumatic actuators are standardly furnished with elevated temperature seals to 302°F. The patented side loaded limit stops never enter the piston chamber eliminating extra possible leak paths.

ACTUATOR FEATURES

- Hard anodized extruded aluminum body
- Concentric spring sets
- Die cast aluminum end caps
- Solid steel barstock pinion (not casting)
- 0°-90° rotation adjustment cam
- 0°-90° rotation adjustment bolts
- POM piston guides
- Minimum air pressure rating: 80 psi
- Maximum air pressure rating: 116 psi
- Working temperature: -4°F - 302°F
- No lubrication maintenance required for the entire actuator lifetime
- 100% factory tested

VALVE FEATURES

- Stainless Steel, ANSI class 150 flanged
- Direct mount ISO 5211/square stem
- Full port, sizes 1" to 4"
- Temperature range -4°F to 400°F
- Blow-out proof stem, adjustable stem packing
- P.T.F.E. seats, packing and thrust washer and FKM Viton O-rings
- Fire safe certified to API 607 6th edition
- 100% tested
- ANSI B16.5, B16.10, B16.34 design
- Antistatic device

PRESSURE - TEMPERATURE CHART FOR SERIES 766000

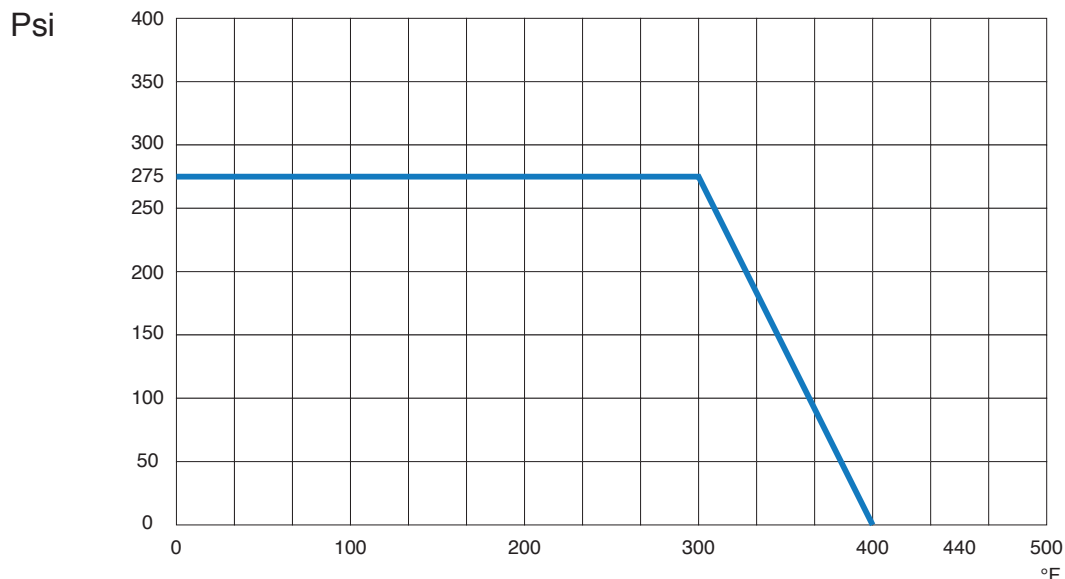

BILL OF MATERIALS FOR 766000

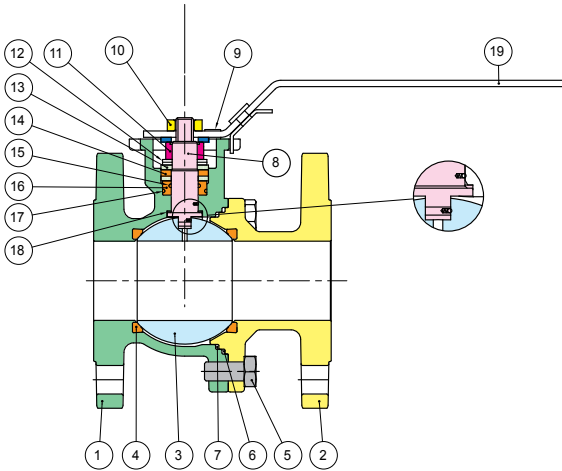

N POS	PART NAME	MATERIAL	N PCS
1	BODY	A351 CF8M	1
2	END CONNECTION	A351 CF8M	1
3	BALL	A479-304/A351 CF8M	1
4	BALL SEATS	P.T.F.E.	2
5	SCREW	STAINLESS STEEL	4-8
6	BODY SEAL	GRAPHOIL	1
7	BODY SEAL	P.T.F.E.	1
8	STEM	A479-30	1
9	SCREW	STAINLESS STEEL	1
10	NUT	STAINLESS STEEL	1

N POS	PART NAME	MATERIAL	N PCS
11	NUT	STAINLESS STEEL	1
12	SPRING WASHER	STAINLESS STEEL	2
13	BUSHING	A479-316	2
14	STEM SEAL	GRAPHOIL	1
15	O-RING	FKM (VITON®)	1
16	STEM SEAL	GRAPHOIL	1
17	O-RING	FKM (VITON®)	1
18	THRUST WASHER	P.T.F.E.	1
19	HANDLE	STAINLESS STEEL	1

DIMENSIONS

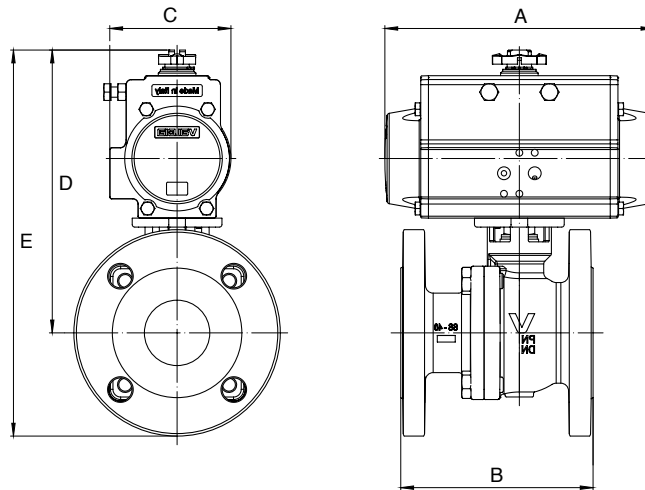

8P766000

766000 W/ **DOUBLE ACTING** ACTUATOR

Size	A	B	C	D	E	ACT. DA
1"	5.55	5.00	2.80	6.29	8.46	52
1-1/2"	6.46	6.50	3.17	7.59	10.15	63
2"	8.27	7.01	3.72	8.70	11.65	75
3"	9.47	7.99	4.17	10.43	14.17	85
4"	10.83	9.02	4.84	11.49	16.02	100

8P766002

766000 W/ **SPRING RETURN** ACTUATOR

Size	A	B	C	D	E	ACT. SR
1"	6.46	5.00	3.17	6.73	8.89	63
1-1/2"	9.47	6.50	3.72	8.85	11.41	85
2"	10.83	7.01	4.84	9.72	12.67	100
3"	14.65	7.99	5.83	12.79	16.49	125
4"	14.65	9.02	5.83	13.34	17.87	125