

HIGH PERFORMANCE BUTTERFLY VALVE

SERIES 8100 - 9100

CARBON STEEL STAINLESS STEEL

Manually operated ANSI 150 class, high performance Wafer style butterfly valves.

- ISO 5211 direct mounting pad/square stem.
- Compact design, easy access to packing.
- Replaceable seat design.
- Multiple V-ring stem packing.
- Reliable and consistent torques.
- R.P.T.F.E seats, metal seats upon request.
- 14" to 24" sizes available upon request.
- 150 WSP.
- Temperature range: -20° F to 475° F.
- Sizes 2" to 12".

G8100-G9100: Gear operated version.

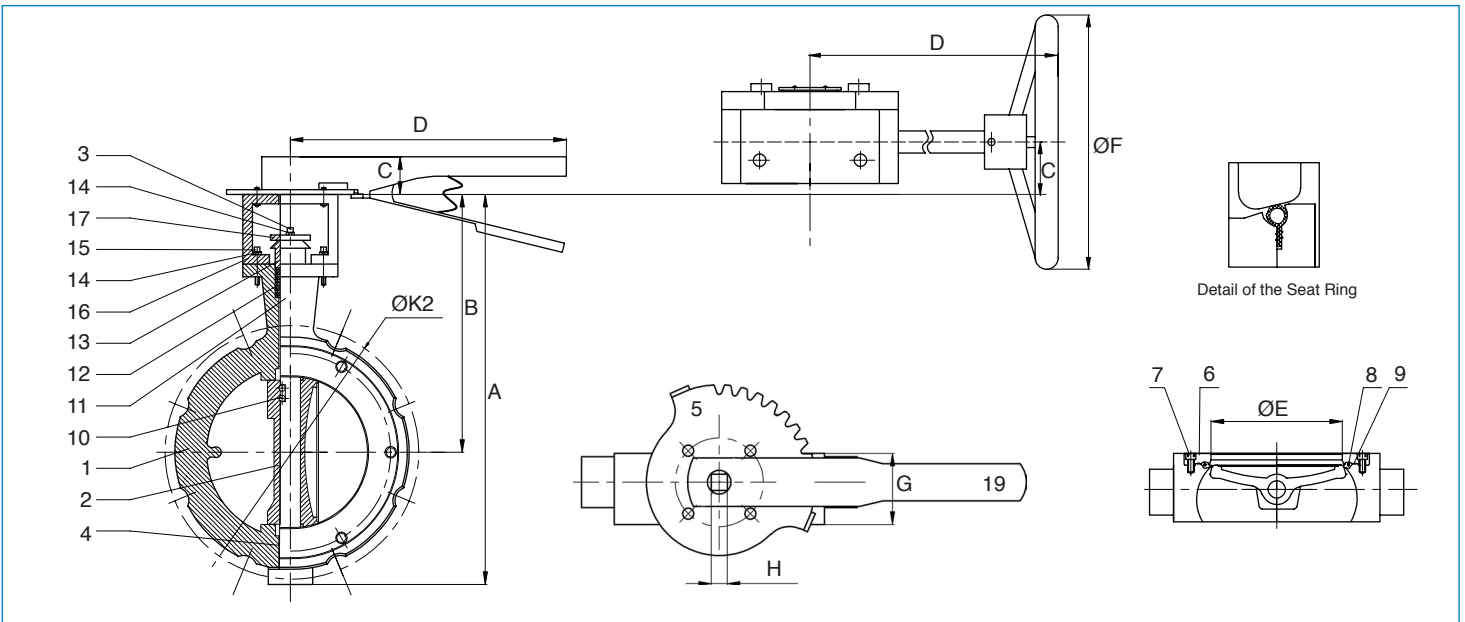

N	POS	PART NAME	MATERIAL	N	PCS
1		BODY	WCB/CF8M	1	
2		DISC	CF8M	1	
3		STEM BOLT	SS 304	2	
4		STEM BUSHING	SS 316 + PTFE	3	
5		PLATE	SS 304	1	
6		SEAT RETAINER	WCB/CF8M	1	
7		RETAINER SCEW	SS 304	6-8	
8		O-RING	VITON®	1	
9		SEAT	CARBON FILLED P.T.F.E	1	
10		PIN	SS 316	2	
11		STEM	AISI 17-4PH	1	
12		V-RING	PTFE	6-9	
13		GLAND BUSHING	SS 316	1	
14		SPRING WASHER	SS 304	4	
15		HEX BOLT	SS 304	4	
16		MOUNTING FLANGE	WCB/CF8M	1	
17		GLAND	CF8M	1	
18		NUT	SS 304	2	
19		HANDLE	MALLEABLE IRON	1	

SIZE	A	B	C	D	ØE	ØF	G	H	ISO 5211	ØK2	Break torque	psi carbon-stainless	Cv	Weight Lbs
2"	9.42	6.42	1.26	10.5	2.45	C/F	1.75	11	F07	4.75 x 4	201	285/275	102	10.14
2-1/2"	9.13	6.42	1.26	10.5	2.91	C/F	1.88	11	F07	5.5 x 4	233	285/275	146	11.24
3"	10.43	7.4	1.26	10.5	3.37	C/F	1.92	11	F07	6 x 4	254	285/275	228	13.45
4"	11.73	8.23	1.26	10.5	4.25	C/F	2.13	14	F07	7.5 x 8	305	285/275	451	17.86
5"	13.95	9.07	1.26	10.5	5.3	C/F	2.25	17	F07	8.5 x 8	576	285/275	714	21.38
6"	14.5	9.6	1.26	10.5	6.4	C/F	2.31	17	F07	9.5 x 8	848	285/275	1103	28.66
8"	16.76	10.75	1.26	13.9	8.35	C/F	2.5	17	F10	11.75 x 8	1505	285/275	2064	46.08
10"	19.26	11.6	1.54	8.9	10.16	11.8	2.81	22	F10	14.25 x 12	2744	285/275	3517	71.65
12"	23.91	14.37	1.54	8.9	11.93	11.8	3.23	27	F14	17 x 12	4602	285/275	4837	121.69