

# 36HLF Series

Model PRH-LF High Capacity  
Pressure Reducing Valve

## SUBMITTAL SHEET

# "Apollo" Valves



Job Name:	
Job Location:	
Engineer:	
Contractor:	
Tag:	
PO#:	
Rep:	
Wholesale Dist.:	

### DESCRIPTION

Apollo® PRH (36H Series) Pressure Reducing Valves are designed for commercial, industrial, and institutional applications to reduce incoming water pressure for protection of plumbing system components and to reduce water consumption. The valves are made with proven ASTM grade bronze and stainless steel materials. The PRH provides high capacity flow with low pressure drop. It is designed with an integral by-pass relief to protect against thermal expansion downstream. The bottom access enables easy in-line cleaning or seat replacement.

### FEATURES

- Sealed Spring Cage for Vault Installation
- Ultra-high Flow Capacity
- Internal Thermal Expansion By-pass
- Local Code Approvals
- Standard Factory Setting: 50 psi
- Three spring ranges cover 10 - 125 psi
- Stainless Steel Bolts and Spring
- 150# ANSI B16.24 Flange Connection Option
- In-line strainer option
- **100% MADE IN THE USA**

### PERFORMANCE RATING

- Maximum Inlet Supply Pressure: up to 400 psig
- Temperature Range: 33 °F - 180 °F

### APPROVALS

- ASSE 1003
- CSA B356

### OPTIONS

- (02) - 10-35 psi
- (03) - 75-125 psi
- (36HLF) - Certified Lead Free

### STANDARD MATERIALS LIST

<b>BODY</b>	Bronze, C89836 Lead Free*
<b>BONNET/CAP</b>	Bronze, ASTM B584
<b>DIAPHRAGM</b>	FDA approved Buna-N w/ Nylon
<b>SEAT DISC</b>	FDA approved EPDM
<b>YOKE</b>	Bronze, C89836 Lead Free*
<b>SPRINGS</b>	Stainless Steel
<b>O-RINGS</b>	FDA approved Nitrile

### DIMENSIONS

Model Number	Part Number	Size (in.)	Dimensions (in.)						Wt. (lbs.) w/strainer	Wt. (lbs.) wo/strainer
			A	B	C	D	E	F		
PRH	36H-203	1/2	4.12	2.25	9.25	1.87	8.37	4.00	7.00	6.0
PRH	36H-204	3/4	4.12	2.25	9.25	2.44	9.00	4.00	8.00	6.0
PRH	36H-205	1	4.82	2.31	9.81	4.00	10.25	4.70	12.00	8.0
PRH	36H-206	1-1/4	6.19	3.19	13.20	3.37	12.50	6.50	29.00	24.0
PRH	36H-207	1-1/2	6.75	3.19	13.20	3.87	13.13	6.50	29.00	23.0
PRH	36H-208	2	8.12	3.50	16.00	4.63	16.00	7.63	47.00	38.0
PRH	36H-209	2-1/2	8.12	3.50	16.00	6.00	17.70	7.63	49.00	37.0
PRH	36H-200	3	10.37	4.00	19.12	7.00	20.50	9.75	87.00	70.0
<b>Flanged</b>										
PRH	36H-709	2-1/2	10.37	3.50	16.00	7.12	21.70	7.63	105.00	55.0
PRH	36H-700	3	12.50	4.00	19.12	8.12	24.50	9.75	132.00	104.0

\* Nominal dimensions are shown. Allowances must be made for manufacturers' tolerances.

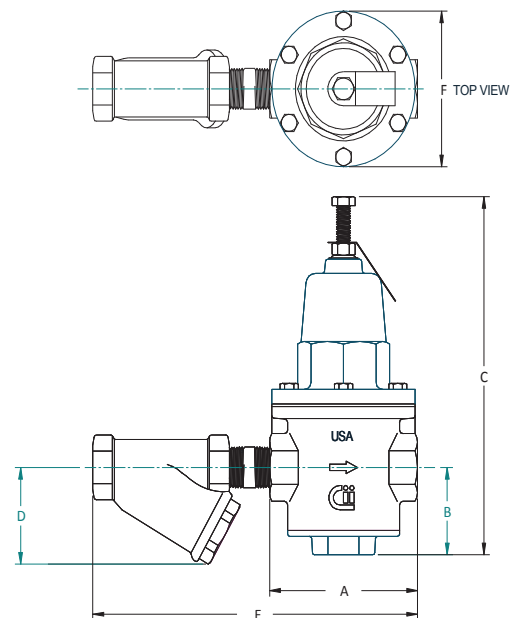

# 36HLF Series

Model PRH-LF High Capacity  
Pressure Reducing Valve

## SUBMITTAL SHEET

"Apollo" Valves

### PART NUMBER

36HLF			
36H - X	X	X	- OX
END CONNECTIONS	OPTIONS	SIZE	PRESSURE RANGE
2 - FNPT x FNPT (Standard)	0 - Standard	3 - 1-1/2"	01 - 25-75 psig (Standard)
7 - Flanged (2-1/2" - 3" only)	1 - With Y-Strainer	4 - 3/4"	02 - 10-35 psig
		5 - 1"	03 - 75-125 psig
		6 - 1-1/4"	
		7 - 1-1/2"	
		8 - 2"	
		9 - 2-1/2"	
		0 - 3"	

### MODEL NUMBER

PRH - X	X	X	X	LF
END CONNECTIONS	ACCESSORIES	PRESSURE ADJ. RANGE	SIZE	
T - Threaded	Y - with Y-Strainer	Standard - 25-75 psig (set at 50)	12 - 1-1/2"	LF - Lead Free
F - ANSI 150# Flanges (2-1/2" - 3" only)		H - 75-125 psig (set at 100)	34 - 3/4"	Blank - Standard Material
		L - 10-35 psig (set at 25)	1 - 1"	
			114 - 1-1/4"	
			112 - 1-1/2"	
			2 - 2"	
			212 - 2-1/2"	
			3 - 3"	

### FLOW CAPACITY (GPM)

Pipe Size	Fall-Off* (PSI)	Pressure Differential (PSI)			Pipe Size	Fall-Off* (PSI)	Pressure Differential (PSI)		
		25	50	75			25	50	75
1/2"	5	8.5	10	11.5	1-1/2"	5	29.8	35.0	40.3
	10	13.6	16	18.4		10	61.5	72.3	83.1
	15	17.9	21	24.2		15	90.1	106.0	121.9
	20	21.3	25	28.8		20	113.1	133.0	153.0
3/4"	5	10.6	12.5	14.4	2"	5	55.3	65.0	74.8
	10	20.4	24.0	27.6		10	126.7	149.0	171.4
	15	28.1	33.0	38.0		15	174.3	205.0	235.8
	20	34.0	40.0	46.0		20	231.2	272.0	312.8
1"	5	17.0	20.0	23.0	2-1/2"	5	58.7	69.0	79.4
	10	29.8	35.0	40.3		10	132.6	156.0	179.4
	15	40.8	48.0	55.2		15	200.6	236.0	271.4
	20	51.0	60.0	69.0		20	271.2	319.0	366.9
1-1/4"	5	21.3	25.0	28.8	3"	5	80.8	95.0	109.3
	10	51.9	61.0	70.2		10	176.0	207.0	238.1
	15	80.8	95.0	109.3		15	282.5	332.4	382.3
	20	106.3	125.0	143.8		20	365.5	430.0	494.5

\* Fall Off is the difference between the PRV's set pressure and the flowing pressure at any given demand.

### PRH SERIES PRV FLOW RATE VS. PRESSURE FALL-OFF

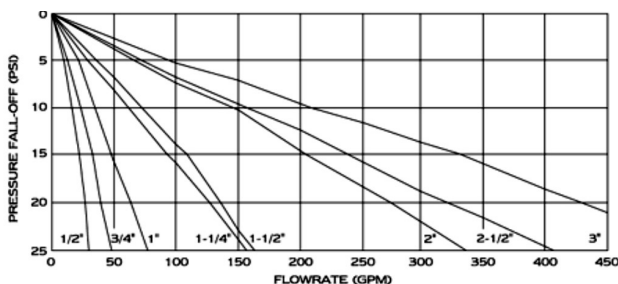

Note: Flow curves are based on static conditions of 100 psi inlet pressure and 50 psi outlet pressure. Pressure Fall-off is the decrease in downstream regulated pressure when the flow increases.