

SERIES 7700

Butterfly Valve



AN-7721-3

Series 7700 butterfly valve with 10 position lever lock



AN-7722-3

Series 7700 butterfly valve with gear operator

Used in commercial grooved-end piping systems 2" through 12".

The uniqueness of the Series 7700 Gruvlok Butterfly Valve begins with the spherical bore of the disc seat area. This facilitates a constant DISC-TO-SEAT loading that maintains a leak tight stem seal regardless of disc position. The stem sealing force is constant through the full disc cycle and operating torques are kept low which increases valve life. The design provides a bubble tight seal from full vacuum to 300 psi when the valve is closed. The valve is rated for dead-end service to a full pressure rating of 300 psi. Silicone Free Series 7700 available upon special request.

The stem-to-disc connection provides zero backlash. The high strength, corrosion resistant, stainless steel stems are blow-out proof. Each stem is fitted with a secondary seal that also provides a lifetime lubrication chamber.

The Series 7700 valve is designed with the contractor in mind. The valve body is a rugged one-piece casting with an integral mounting base for gear operator or handle actuation, while providing room for a minimum of 2" of pipe insulation. The valve is designed and manufactured to meet or exceed the requirements of MSS SP-67.

For data on fire protection listings/approvals, contact your Anvil representative.

NSF/ANSI 61

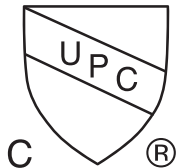

2" - 10" Series 7700
 Certified to NSF/ANSI 61
 (cold water) and Annex G
LEAD FREE

PROJECT INFORMATION		APPROVAL STAMP	
Project:		<input type="checkbox"/> Approved	
Address:		<input type="checkbox"/> Approved as noted	
Contractor:		<input type="checkbox"/> Not approved	
Engineer:		Remarks:	
Submittal Date:			
Notes 1:			
Notes 2:			

SERIES 7700

Butterfly Valve

MATERIAL SPECIFICATIONS

1. **BODY:** Ductile Iron conforming to ASTM A 536, Grade 65-45-12
Body Coating: Nylon (For nylon coating resistance, see table on page 81.)
2. **DISC:** Ductile Iron conforming to ASTM A 536 Grades 65-45-12
Disc Encapsulation: Properties as specified in accordance with ASTM D 2000.
 - Grade E (EPDM):** Service Temperature Range -40°F to +230°F (-40°C to +110°C)
 Recommended for water service, dilute acids, alkalies, oil-free air and many chemical services.
 NOT FOR USE IN PETROLEUM SERVICES.
 - Grade T (Nitrile):** Service Temperature Range -20°F to +180°F (-29°C to +82°C)
 Recommended for petroleum products, air with oil vapors, vegetable oils and mineral oils.
 NOT FOR USE IN HOT WATER SERVICES.
- 3, 4. **UPPER AND LOWER SHAFT:** Type 416 Stainless Steel
5. **O-RINGS:** Compatible with disc coating
- 6, 7. **TOP AND BOTTOM BRONZE SLEEVE BUSHINGS:** 8", 10", & 12" Valve only

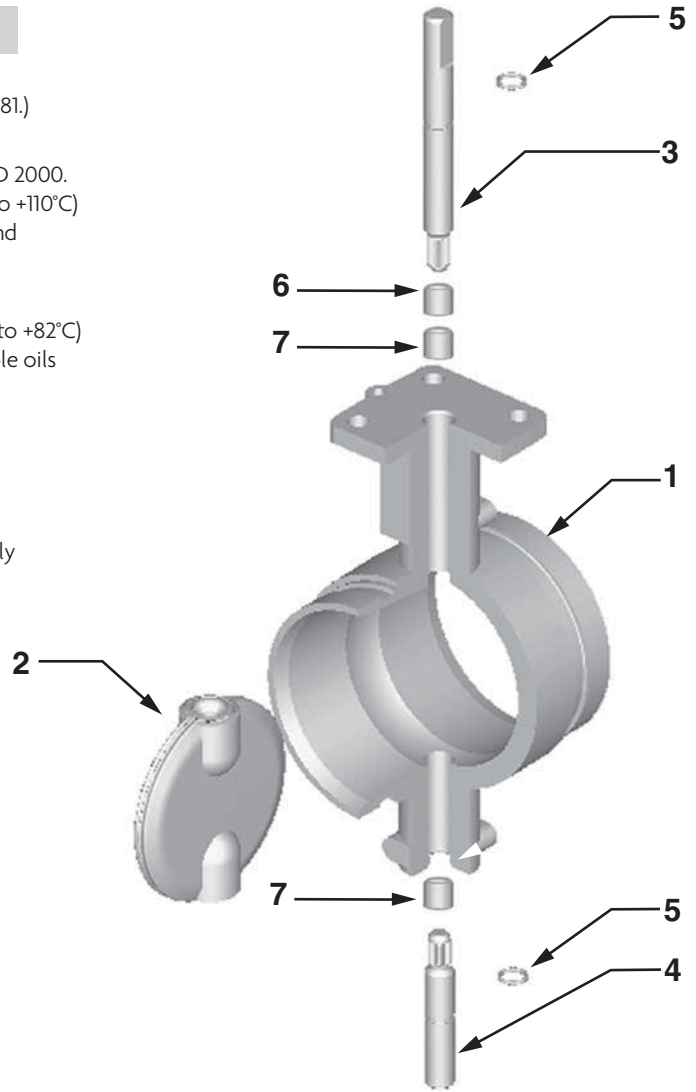

GRUVLOK BUTTERFLY VALVE SERIES 7700 (ORDERING INFORMATION)

Sample Part Number	8"	A	N	77	2	1 -	3	Special
8" AN7721-3 →	Size	Body Style	Body Coating	Series	Disc Coating	Operator	Stem	
	2" - 12"	A	N - Nylon	77-77XX	1 - Nitrile (Grade T) 2 - EPDM (Grade E)	0 - None 1 - 10 Pos. L/Lock 2 - Gear Operator D - Infinite Pos. w/Memory Stop 4 - Short 10 Pos. L/lock Operator	3 - 416 S.S.	SF - Manufactured without Silicone

NOTE: For operator safety, hand levers on 8" valves are limited to applications with a 25 PSI (1.7 bar) maximum pressure.
 For operator safety, hand levers on 10" and 12" valves are not available.

SERIES 7700

Butterfly Valve

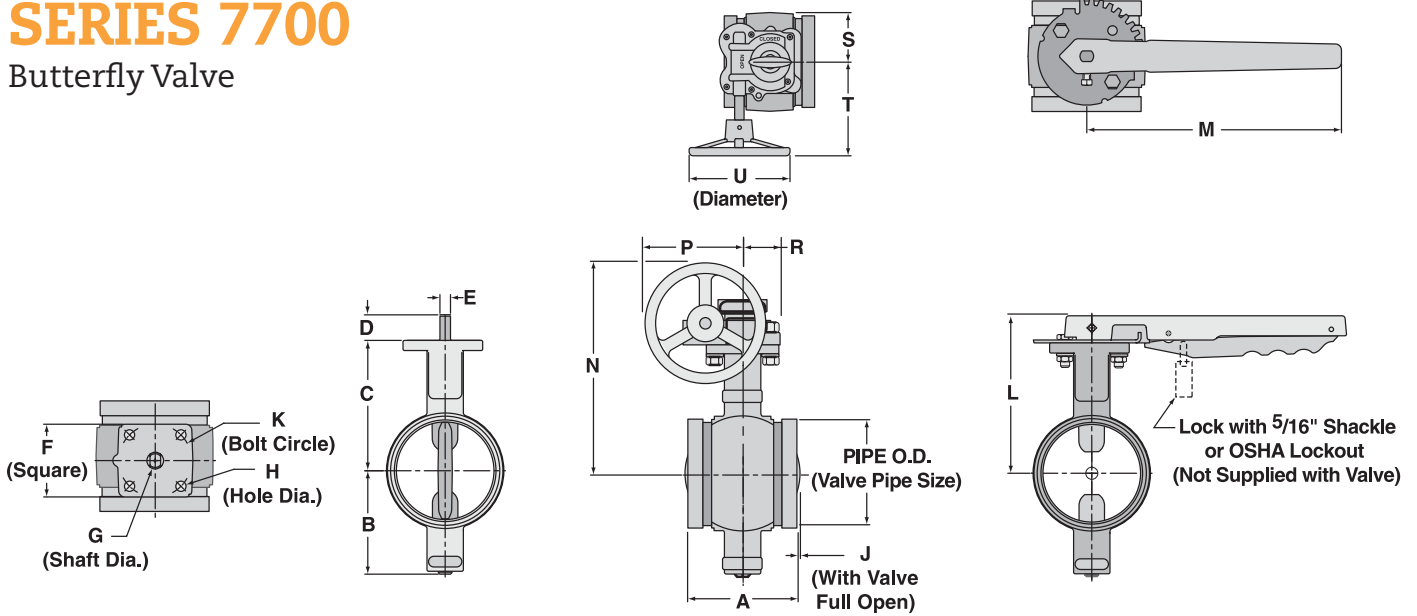

SERIES 7700 BUTTERFLY VALVE DIMENSIONS

Dimensions	Valve Size (ANSI/DN)									
	2	2½	3	4	5	6	8	10	12	
<i>In./mm</i>	50	65	80	100	125	150	200	250	300	
O.D.	2¾	2⅞	3½	4½	5⅞	6⅝	8⅝	10¾	12¾	
<i>In./mm</i>	60.3	73.0	88.9	114.3	141.3	168.3	219.1	273.1	323.9	
A	3⅜	3⅜	3⅜	4⅝	5⅜	5⅜	5¼	6¼	6½	
	81.0	96.8	96.8	117.3	147.6	147.6	133.4	158.8	165.1	
B	3	3⅜	3⅜	4¼	5	5½	6⅜	8	9	
	75.4	80.8	96.5	108.5	126.5	138.9	175.8	202.9	229.4	
C	4⅜	4⅞	5⅜	5⅞	5⅞	6⅜	7¾	9½	10½	
	105.9	111.3	129.0	136.7	149.4	161.8	196.9	240.3	266.7	
D	1⅜	1⅜	1⅜	1⅜	1⅜	1⅜	1⅝	1⅝	1⅝	
	26.9	26.9	26.9	26.9	26.9	26.9	41.1	41.1	41.1	
E	⅞	⅞	⅞	⅞	⅞	⅞	¾	¾	¾	
	11.1	11.1	11.1	11.1	11.1	11.1	19.1	19.1	19.1	
F	3	3	3	3	3	3	5	5	5	
	76.2	76.2	76.2	76.2	76.2	76.2	127.0	127.0	127.0	
G	⅞	⅞	⅞	⅞	⅞	⅞	1	1¼	1¼	
	14.3	14.3	14.3	14.3	22.2	22.2	25.4	31.8	31.8	
H	⅞	⅞	⅞	⅞	⅞	⅞	½	½	½	
	11.1	11.1	11.1	11.1	11.1	11.1	13.5	13.5	13.5	
J	-	-	-	-	-	⅛	1⅜	1⅞	2¾	
	-	-	-	-	-	3.3	34.8	47.0	70.1	
K	3	3	3	3	3	3	5	5	5	
	76.2	76.2	76.2	76.2	76.2	76.2	127.0	127.0	127.0	
L	5⅜	5½	6¼	6½	7	7½	9⅞	-	-	
	135.1	140.5	158.2	165.9	178.6	191.0	240.3	-	-	
M	10½	10½	10½	10½	10½	10½	15	-	-	
	266.7	266.7	266.7	266.7	266.7	266.7	381.0	-	-	
N	7⅜	8	8⅜	9	9½	10	14⅜	16⅞	20⅜	
	198.0	203.3	221.1	228.7	241.4	253.9	379.2	422.7	525.3	
P	4	4	4	4	4	4	8⅜	8⅜	11⅞	
	102.1	102.1	102.1	102.1	102.1	102.1	204.5	204.5	295.4	
R	1½	1½	1½	1½	1½	1½	2⅜	2⅜	2⅞	
	38.2	38.2	38.2	38.2	38.2	38.2	58.5	58.5	65.5	
S	2	2	2	2	2	2	2⅝	2⅝	3¼	
	51.0	51.0	51.0	51.0	51.0	51.0	66.0	66.0	83.0	
T	6⅜	6⅜	6⅜	6⅜	6⅜	6⅜	10⅜	10⅜	13⅜	
	160.3	160.3	160.3	160.3	160.3	160.3	275.3	275.3	350.3	
U	5	5	5	5	5	5	12	12	18	
	127.0	127.0	127.0	127.0	127.0	127.0	304.8	304.8	457.2	

Note: 3" or 5" handwheels may be included on valves sizes 2" - 4". Contact your Anvil Rep. for additional information.

SERIES 7700

Butterfly Valve Performance Data

Maximum Working Pressure Rating: 300 PSI

(Commercial Applications - Sizes 2" thru 12")

CV VALUES									
Valve Size	O.D.	Disc Position (degrees open)							
		25°	30°	40°	50°	60°	70°	80°	90°
In./mm	In./mm								
2	2.375	4	7	19	44	48	80	111	158
50	60.3	0.3	0.5	1.3	3.0	3.3	5.5	7.7	10.9
2½	2.875	9	14	34	78	84	142	196	280
65	73.0	0.6	1.0	2.3	5.4	5.8	9.8	13.5	19.3
3	3.500	14	20	50	112	128	215	285	400
80	88.9	1.0	1.4	3.4	7.7	8.8	14.8	19.7	27.6
4	4.500	29	41	100	239	250	420	582	826
100	114.3	2.0	2.8	6.9	16.5	17.2	29.0	40.1	57.0
5	5.563	62	76	182	415	445	780	1,100	1,480
125	141.3	4.3	5.2	12.5	28.6	30.7	53.8	75.8	102.0
6	6.625	96	141	325	755	809	1,370	1,920	2,678
150	168.3	6.6	9.7	22.4	52.1	55.8	94.5	132.4	184.6
8	8.625	172	252	592	1,365	1,460	2,430	3,410	4,819
200	219.1	11.9	17.4	40.8	94.1	100.7	167.5	235.1	332.3
10	10.750	230	328	792	1,825	1,962	3,260	4,590	6,431
250	273.1	15.9	22.6	54.6	125.8	135.3	224.8	316.5	443.4
12	12.750	418	604	1,440	3,350	3,590	5,980	8,750	11,947
300	323.9	28.8	41.6	99.3	231.0	247.5	412.3	603.3	823.7

HEADLOSS EQUIVALENT LENGTH OF PIPE					
Valve Size	O.D.	Equivalent Feet of Pipe* C=120			Max. Insulating Thickness
		Sch. 10	Sch. 30	Sch. 40	
In./mm	In./mm	Ft./m			In./mm
2	2.375	5.8	-	4.7	2
50	60.3	1.8	-	1.4	50
2½	2.875	5.1	-	3.7	2½
65	73.0	1.6	-	1.1	65
3	3.500	9.6	-	7.2	2
80	88.9	2.9	-	2.2	50
4	4.500	7.5	-	5.7	2½
100	114.3	2.3	-	1.7	65
5	5.563	7.0	-	5.6	2½
125	141.3	2.1	-	1.7	65
6	6.625	6.1	-	4.8	2½
150	168.3	1.9	-	1.5	65
8	8.625	6.3	5.7	-	2½
200	219.1	1.9	1.7	-	65
10	10.750	11.3	10.2	-	3
250	273.1	3.4	3.1	-	80
12	12.750	8.4	7.4	-	3½
300	323.9	2.6	2.3	-	90

* The equivalent feet of pipe is based on the Hazen and Williams formula and the flow rates typically used with each size valve.

VALVE WEIGHT AND TORQUE VALUES							
Valve Size	O.D.	* Approx. Wt. Ea.	Operating Pressure				
			50 PSIG	100 PSIG	150 PSIG	200 PSIG	300 PSIG
In./mm	In./mm	Lbs./Kg	† Breakaway Torque (In. - Lbs) / N-m				
2	2.375	5	72	90	100	120	200
50	60.3	2.3	8.1	10.2	11.3	13.6	22.6
2½	2.875	10	105	126	144	162	250
65	73.0	4.5	11.9	14.2	16.3	18.3	28.2
3	3.500	11	126	139	168	195	425
80	88.9	5.0	14.2	15.7	19.0	22.0	48.0
4	4.500	15	265	285	320	355	800
100	114.3	6.8	29.9	32.2	36.2	40.1	90.4
5	5.563	20	491	578	615	674	850
125	141.3	9.0	55.5	65.3	69.5	76.2	96.0
6	6.625	46	625	678	760	820	1,650
150	168.3	20.9	70.6	76.6	85.9	92.7	186.4
8	8.625	68	1,170	1,400	1,640	1,760	3,200
200	219.1	30.8	132.2	158.2	185.3	198.9	361.6
10	10.750	78	1,930	2,375	2,860	3,100	6,000
250	273.1	35.4	218.1	268.4	323.2	350.3	678.0
12	12.750	91	2,900	3,420	4,760	5,600	11,000
300	323.9	41.3	327.7	386.4	537.9	632.8	1,242.9

† These values are valid for water and lubricating fluid service only.
 Contact Anvil for information on torques for dry and non-lubricating fluid service.
 * Weights may vary based on valve options selected.

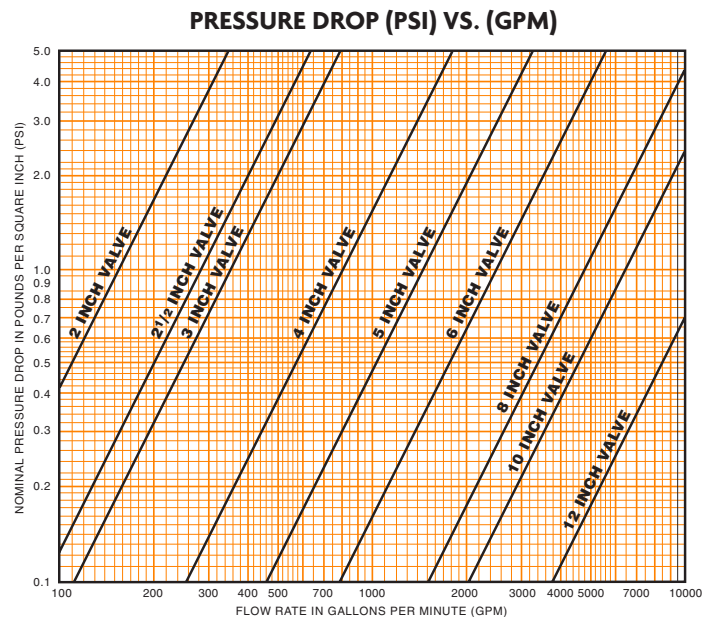

SERIES 7700

Butterfly Valve

Resistance to various chemicals, as a function of temperature °F (Fahrenheit)

NYLON COATING

Coating Condition after 18 months immersion

RESISTANCE				
	68°F	104°F	140°F	176°F
Alcohols				
benzyl alcohol	L	P	P	P
butanol	G***	L	P	
ethanol (pure)	G***	G	L	
glycerine (pure)	G	G	L	P
glycol	G	G	G	P
methanol (pure)	G***	L	P	
Chlorinated solvents				
carbon tetrachloride	P			
methyl bromide	G	P		
methyl chloride	G	P		
perchloroethylene	G	G	L	
trichloroethane	L	P		
trichloroethylene	G	L		
Phenols				
	P	P	P	P
Various Organic Compounds				
anethole	G			
carbon disulphide	G***	L**	P	
diacetone alcohol	G	G***	L	P
dimethyl formamide	G	G	L	
ethylene chlorhydrin	P	P		
ethylene oxide	G	G	L	P
furfural	G	G***	L	P
glucose	G	G	G	G
tetraethyl lead	G			
tetrahydrofurare	G	G	L	
Salts, esters, ethers				
amyl acetate	G	G	G	L
butyl acetate	G	G	G	L
diethyl ether		G		
diocetylphosphate	G	G	G	L
diocetylphthalate	G	G	G	L
ethyl acetate	G	G	G	
fatty acid esters	G	G	G	G
methyl acetate	G	G	G	
methyl sulfate	G	L		
tributylphosphaate	G	G	G	L
tricresylphosphate	GG	G	G	L
Various Products				
beer	G			
cider	G			
crude petroleum	G	G	G***	
diesel fuel	G	G	G***	
fruit juices	G	G		
fuel-oil	G	G	G	
greases	G	G	G	G
ground nut oil	G	G		
high octane gasoline	G	G	G***	
kerosene (paraffin)	G	G	G***	
linseed cake	G	G	G	G
milk	G	G	G	G
mustard	G			
normal gasoline	G	G	G***	
oils	G	G	G	G

RESISTANCE				
	68°F	104°F	140°F	176°F
Various Products (cont'd.)				
solutions or emulsions of D.D.T. or lindane hydroxy-quinoline (agricultural sprays)	G			
soap solution	G			
stearin	G	G	G	
solvent naptha	G	G	G***	
natural gas	G	G		
turpentine	G	G	G***	
vinegar	G			
wine	G			
Inorganic Acids				
chromic acid (10%)	P	P	P	P
hydrochloric acid (1%)	G	L	P	P
hydrochloric acid (10%)	G	L	P	P
nitric acid (all concentrations)	P	P	P	P
phosphoric acid (50%)	G	L	P	P
sulphuric acid (1%)	G	L	L	P
sulphuric acid (10%)	G	L	P	P
sulphur trioxide	L	P	P	P
Other Inorganic products				
agriculture sprays	G	G		
bleach solutions	L	P	P	P
bromine	P	P		
chlorine	P	P	P	P
fluorine	P	P	P	P
hydrogen	G	G	G	G
hydrogen peroxide (20 volumes)	G	L		
mercury	G	G	G	G
oxygen	G	G	L	P
ozone	L	P	P	P
potassium permanganate (5%)	P	P		
sea water	G	G	G	
soda water	G	G	G	G
sulphur	G	G		
water	G	G	G	L
Aldehydes & Ketones				
acetaldehyde	G	L	P	
acetone	G	G***	L	P
benzaldehyde	G	L	P	
cyclohexanone	G	L	P	
formaldehyde (technical grade)	G	L	P	
methylethylketone (MEK)	G	G	L	P
methylethylketone (MIBK)	G	G	L	P
Hydrocarbons				
acetylene	G	G	G	G
benzene	G	G***	L	
butane	G	G	G	
cyclohexane	G	G	G	L
decaline	G	G	G	L
HFA (Forane®)	G			
hexane	G	G	G	
methane	G	G	G	
naphthalene	G	G	G	L
propane	G	G	G	
styrene	G	G***		

RESISTANCE				
	68°F	104°F	140°F	176°F
Hydrocarbons (cont'd.)				
tulene	G	G***	L	L
xylene	G	G***	L	L
Inorganic Bases				
ammonium hydroxide (concentrated)	G	G	G	G
ammonia (liquid or gas)	G	G		
lime-wash	G	G	G	
potassium hydroxide (50%)	G	L	P	P
sodium hydroxide (5%)	G	G	L	
sodium hydroxide (10%)	G	L	L	
sodium hydroxide (50%)	G	L	P	P
Organic acids & anhydrides				
acetic acid	L	P	P	P
acetic anhydrie	L	P	P	P
citric acid	G	G	L	P
formic acid	P	P	P	P
lactic acid	G	G	G	L
oleic acid	G	G	G	L
oxalic acid	G	G	L	P
picric acid	L	P	P	P
tartaric acid (saturated solution)	G	G	G	L
uric acid	G	G	G	L
Inorganic Salts				
alum	G	G	G	
aluminium sulphate	G	G	G	G
ammonium nitrate	G	G	G	
barium chloride	G	G	G	G
calcium arsenate (concentrated solutions or slurries)	G	G	G	
calcium chloride	G	G	G	G
calcium sulphate	G	G	L	
copper sulphate	G	G	G	G
diammonium phosphate	G	G	L	
magnesium chloride (50%)	G	G	G	G
potassium ferrocyanide	G	G	G	
potassium nitrate	G*	L*	P	P
potassium sulphate	G	G	G	G
sodium carbonate	G	G	L	P
sodium chloride (saturated)	G	G	G	G
sodium silicate	G	G	G	
sodium sulphide	G	L	L	
trisodium phosphate	G	G	G	G
Organic bases				
aniline (pure)	L	P	P	P
diethanolamine (20%)	G	G***	G***	L
pyridine (pure)	L	P	P	P
urea	G	G	L	L

LEGEND	
*	= Slight Yellowing
**	= Yellowing
***	= Swelling observed
G	= Good
L	= Limited
P	= Poor