

Tech Data

Viega ProPress® Zero Lead Manual Balancing Valve, Model 2980ZL



Description

Viega's ProPress Manual Balancing Valve is a fixed orifice style valve with a venturi insert. The valve features high accuracy with the multi-turn functionality, a positive shut off with memory

stop, and Viega's Smart Connect® technology for easy identification of unpressed connection during testing.

Features

- DZR lead-free brass
- PT ports
- ProPress press-ends with Smart Connect technology
- Positive shut-off with memory stop
- Tolerance on nominal Cvs $\pm 3\%$

Operating Parameters

- 300 WOG
- Temperature Range Water:
 - 15°F to 250°F
 - Below 32°F only for water with added antifreeze fluids
- Max Operating Pressure: 250 psi



This document is subject to updates. For the most current Viega technical literature, please visit www.viega.us.



Viega products are designed to be installed by licensed and trained plumbing and mechanical professionals who are familiar with Viega products and their installation. **Installation by non-professionals may void Viega LLC's warranty.**



Zero Lead identifies Viega products meeting the lead free requirements of NSF/ANSI/CAN 61 through testing under NSF/ANSI/CAN 372 (0.25% or less maximum weighted average lead content).

Listings and Certifications

- ASTM B927 C27453
- NSF®-61-372
- UNS C35330
- UL 2043 classification

Approved Applications

- HVAC
- Potable water

Viega ProPress Manual Balancing Valve - Model 2980ZL

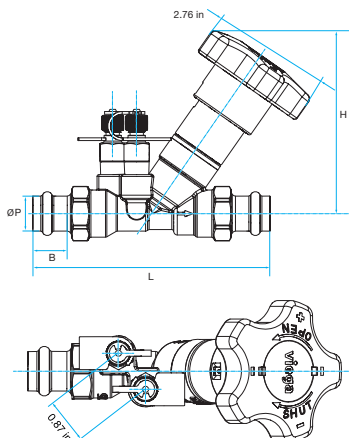

Part No.	Size (in)	ΦC^1 (in)	H (in)	L (in)	B (in)	Weight (lbs)	Flow Range (GPM)
82100	U-1/2	0.627-0.631	4.06	5.157	0.827	1.23/1.16	0.27-0.71
82105	L-1/2	0.627-0.631	4.06	5.157	0.827	1.23/1.16	0.49-1.17
82110	1/2	0.627-0.631	4.06	5.157	0.827	1.23/1.16	0.98-2.35
82115	3/4	0.877-0.881	4.06	5.846	0.905	1.43/1.34	2.19-5.15
82120	1	1.128-1.131	4.06	6.181	0.906	1.73/1.55	4.09-9.56
82125	1 1/4	1.378-1.381	4.85	6.996	1.024	2.78/2.53	8.56-19.81
82130	1 1/2	1.628-1.632	4.94	7.921	1.417	3.50/3.16	12.84-29.80
82135	2	2.128-2.132	5.34	6.138	1.575	4.80/4.46	24.09-55.63

¹ Tolerance field

Components

#	Component	Material
1	Nut	Steel / Zn plated
2	Handwheel	ABS (grey)
3	Screw	Steel
4	Stop spring ring	Spring Steel
5	Bonnet	DZR Lead Free Brass
6	Stem	Brass
7	Union ¹	DZR Lead Free Brass
8-9	Stem O-ring	EPDM Perox
10	Shutter	DZR Lead Free Brass
11	Disco O-ring ¹	EPDM Perox
12	Disc ¹	DZR Lead Free Brass
13	Gasket disc	PTFE
14	Balance cone	DZR Lead Free Brass
15	Body	DZR Lead Free Brass
16-19	Venturi insert	DZR Lead Free Brass
20	Test point	DZR Brass ²

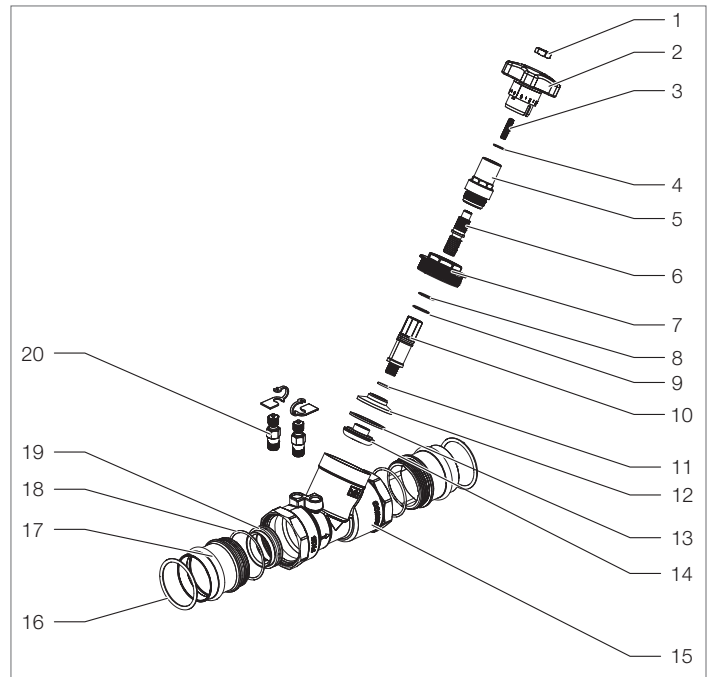

¹ Only on 1¼", 1½", and 2"

² Test points with EPDM Perox gaskets and polypropylene ties

Performance

To obtain the best performances, valve must be installed on a pipe followed by straight pipe lengths as per figure indications.

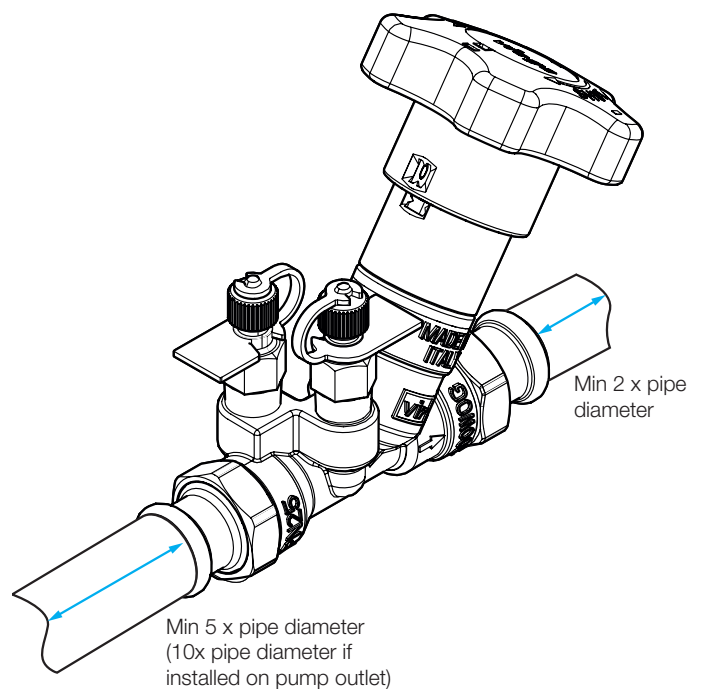

Flow Measurement

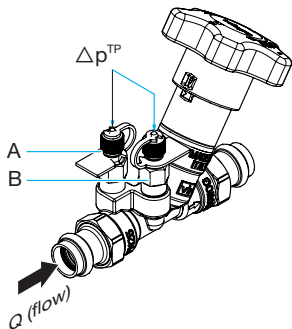
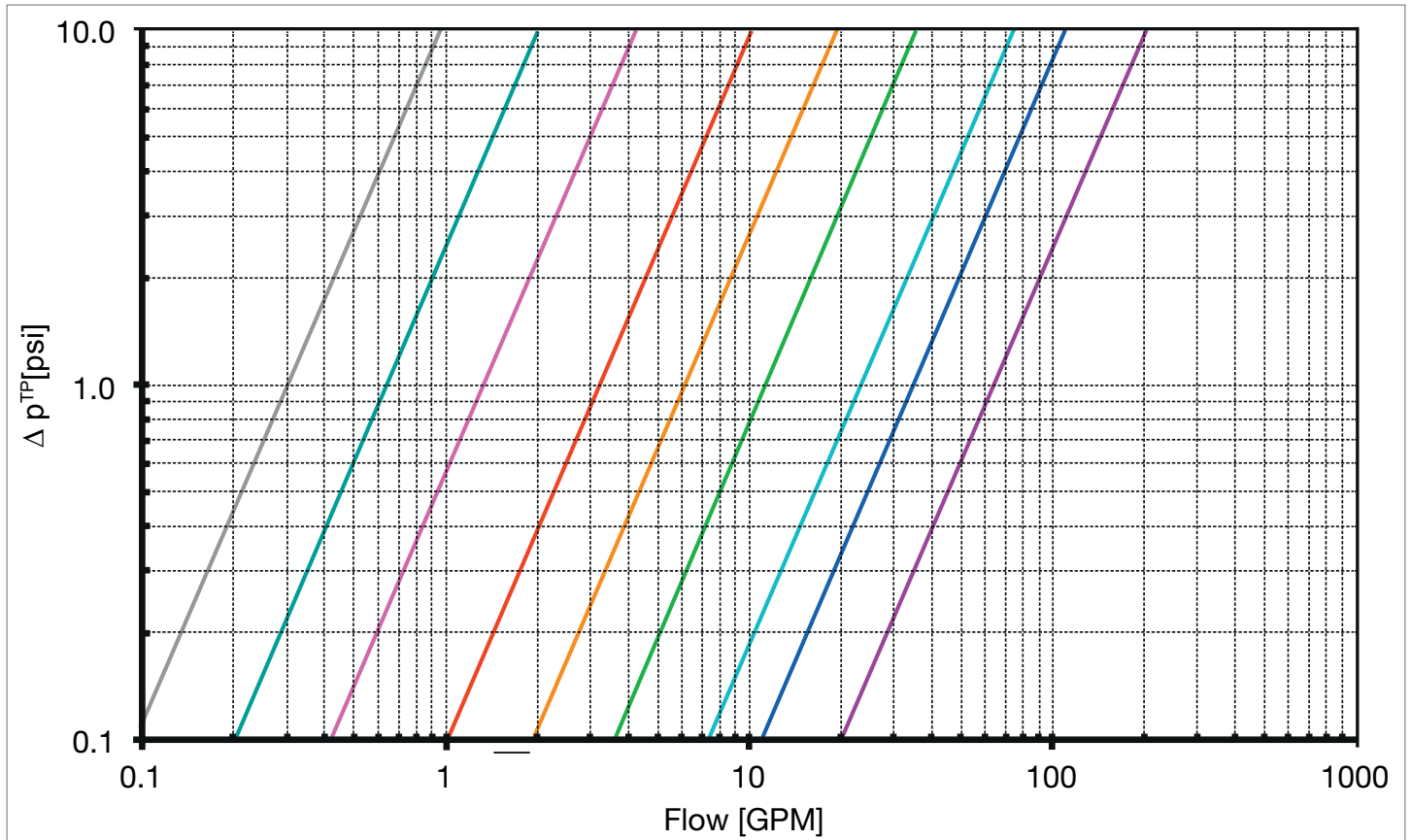

A = High pressure test point (red)
 B = Low pressure tet point (blue)
 Q = Flow rate in GPM
 Δp = Differential pressure signal generated through pressure test points
 C_{vs} = Flow coefficient across valve seat

$$Q = C_{vs}^{venturi} \cdot \sqrt{\Delta p^{TP}}$$

(see chart above)

U-1/2"	C _{vs} venturi	0.64
L-1/2"	C _{vs} venturi	0.63
1/2"	C _{vs} venturi	3.24
3/4"	C _{vs} venturi	6.16
1"	C _{vs} venturi	11.24
1 1/4"	C _{vs} venturi	23.41
1 1/2"	C _{vs} venturi	34.95
2"	C _{vs} venturi	63.77

Headloss Calculation

Handwheel Position	Cv Values (GPM @ 1psi)							
	U-1/2"	L-1/2"	1/2"	3/4"	1"	1 1/4"	1 1/2"	2"
0.5	0.177	0.160	0.474	0.47	1.70	2.96	3.14	6.20
0.7	0.206	0.186	0.474	0.54	2.00	3.38	3.61	7.56
1.0	0.283	0.287	0.613	0.67	2.42	3.95	4.27	9.65
1.3	0.331	0.394	0.717	0.81	2.82	4.49	4.96	12.19
1.5	0.355	0.440	0.809	0.90	3.12	4.83	5.57	14.30
1.7	0.387	0.501	0.902	0.99	3.48	5.25	6.60	16.64
2.0	0.445	0.586	0.99	1.12	4.13	6.27	8.99	20.17
2.3	0.511	0.67	1.10	1.25	4.83	7.82	12.08	23.35
2.5	0.517	0.70	1.18	1.39	5.28	9.16	14.21	25.12
2.7	0.527	0.74	1.32	1.62	5.63	10.46	16.34	26.66
3.0	0.563	0.83	1.60	2.24	6.09	12.21	18.89	28.72
3.3	0.578	0.86	1.88	2.94	6.49	13.39	20.67	30.57
3.5	0.594	0.89	2.03	3.39	6.64	13.94	21.54	31.72
3.7	0.595	0.92	2.12	3.75	6.80	14.34	22.16	32.86
4.0	0.603	0.95	2.19	4.06	7.10	14.50	22.65	34.36
4.4	0.605	0.98	2.22	4.24	7.21	—	—	—

Formula linking flow Q (in GPM) and theoretical valve headloss Δp (in psi). C_v depends on handwheel position as indicated in table.

$$\Delta p = \left(\frac{Q}{C_v} \right)^2$$

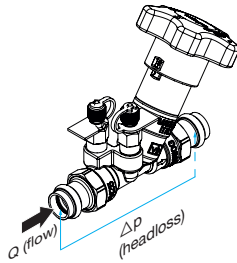

Q = Flow rate in GPM

Δp = Total headloss of the system

C_v = Flow coefficient

Presetting

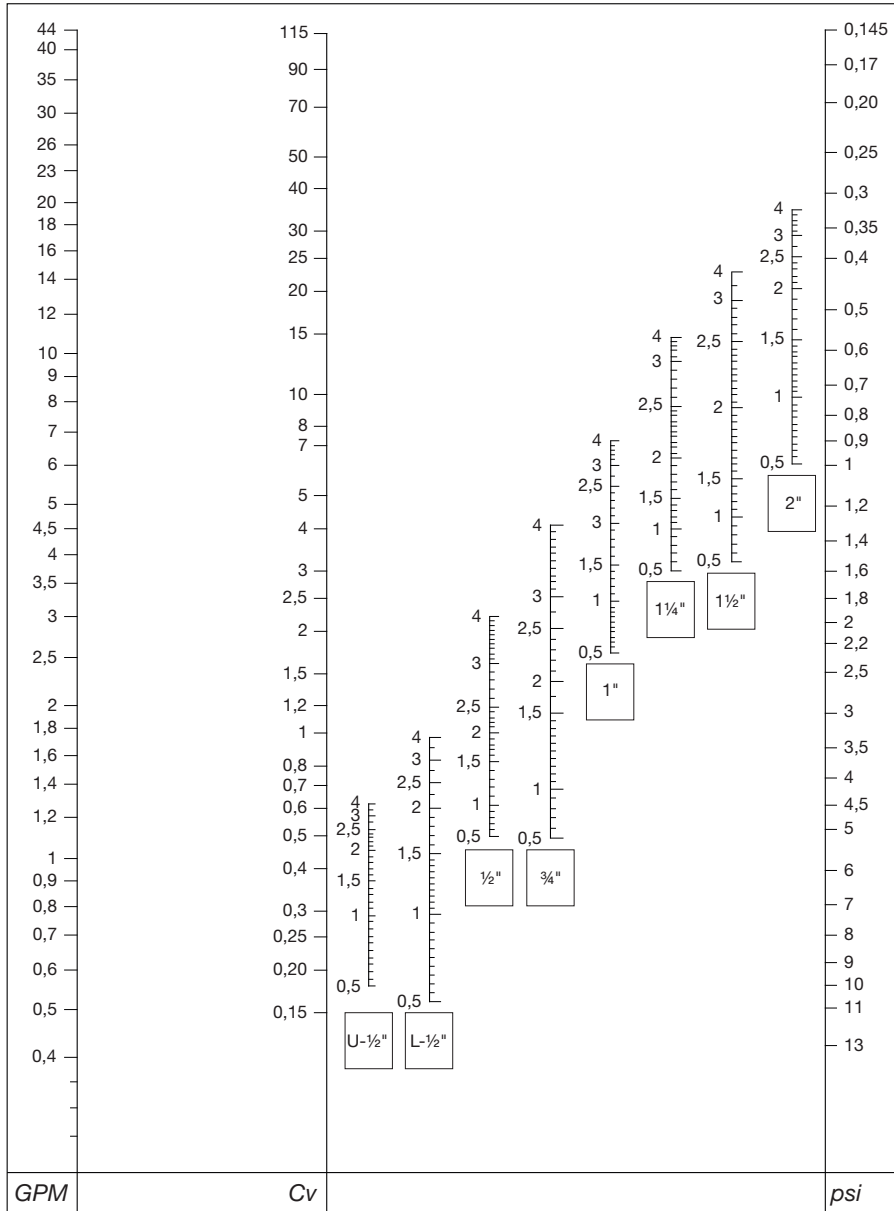

Using the diagram to the left, it is possible to determine the presetting position of the valve with the given design flowrate and headloss:

1. Draw a straight line joining design flowrate and design headloss;
2. Determine design Cv value as intersection of drawn line and Cv axis;
3. Draw a straight horizontal line from intersection previously identified and the specific valve size Axis
4. Intersection determines handwheel position to use for presetting.

In the example below, for a design flowrate of 5GPM and design Δp 3psi, a handwheel position of 1.35 is determined for a 1" valve.

